

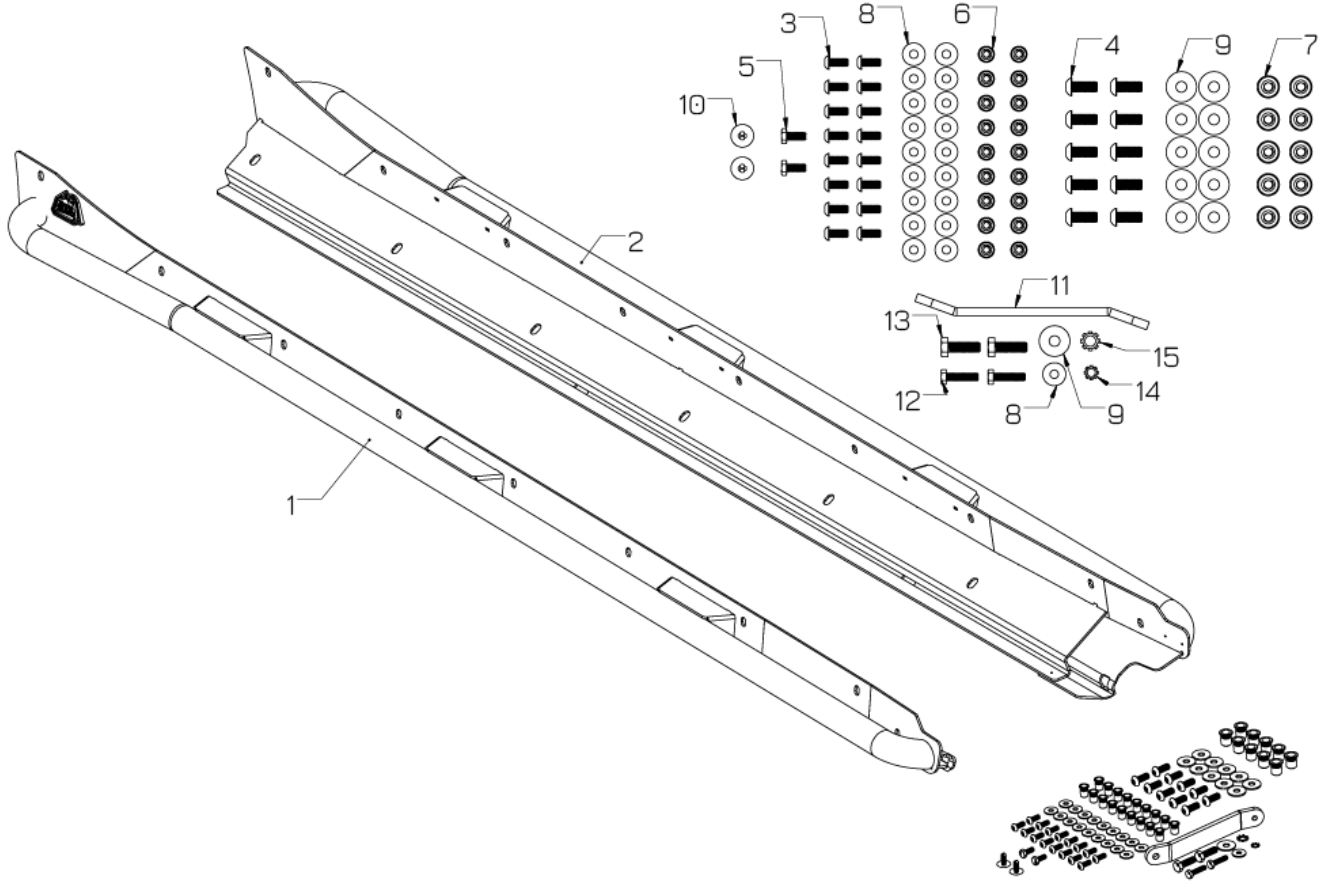

79-27019 aFe Power Terra Guard Off-Road Slider Subaru Crosstrek 18-23 GT Platform



Item	Description	P/N	Qty
1	RT Slider Assembly: GT Crosstrek	05-61494	1
2	LF Slider Assembly: GT Crosstrek	05-61495	1
3	Screw, Btn Hd Socket: M6x1x15, SS Black	03-50795	16
4	Screw, Btn Hd Socket: M8x1.25x20, SS Black	03-50796	10
5	Screw, Hex head M6-1x16mm SS Black	03-50812	2
6	Rivet, Nut: M6	03-50799	18
7	Rivet, Nut: M8	03-50798	10
8	Washer, M6 Fender, SS Black	03-50810	17
9	Washer, M8 Fender, SS Black	03-50811	11
10	Retainer Clip, Christmas Tree Style: 9/32" Hole	03-50616	2
11	Tool, Rivnut M6/M8	03-50801	1
12	Screw, Hex Head: M6x1x25mm	03-50114	2
13	Screw, Hex Head: M8x1.25x25mm	03-50421	2
14	Washer, Ext Star Lock M6	03-50803	1
15	Washer, Ext Star Lock M8	03-50804	1



- Please read the entire instruction manual before proceeding.
- Ensure all components listed are present.
- For technical support please call 951-493-7185.
- Ensure you have all necessary tools before proceeding.
- Retain factory parts for future use.

Procedure:

1. This installation can be done with the vehicle on the ground. But, for an easier installation, drive the vehicle onto floor ramps or 4-post rack. Steer the front wheels towards the side you are working on. This will allow more space to work on the inner fender area.



2. Locate the backside of the wheel well area and remove (3) screw-in clips just behind the front wheel.





3. Remove the (5) pop clips & (2) screw-in clip at the bottom of the rocker panel.

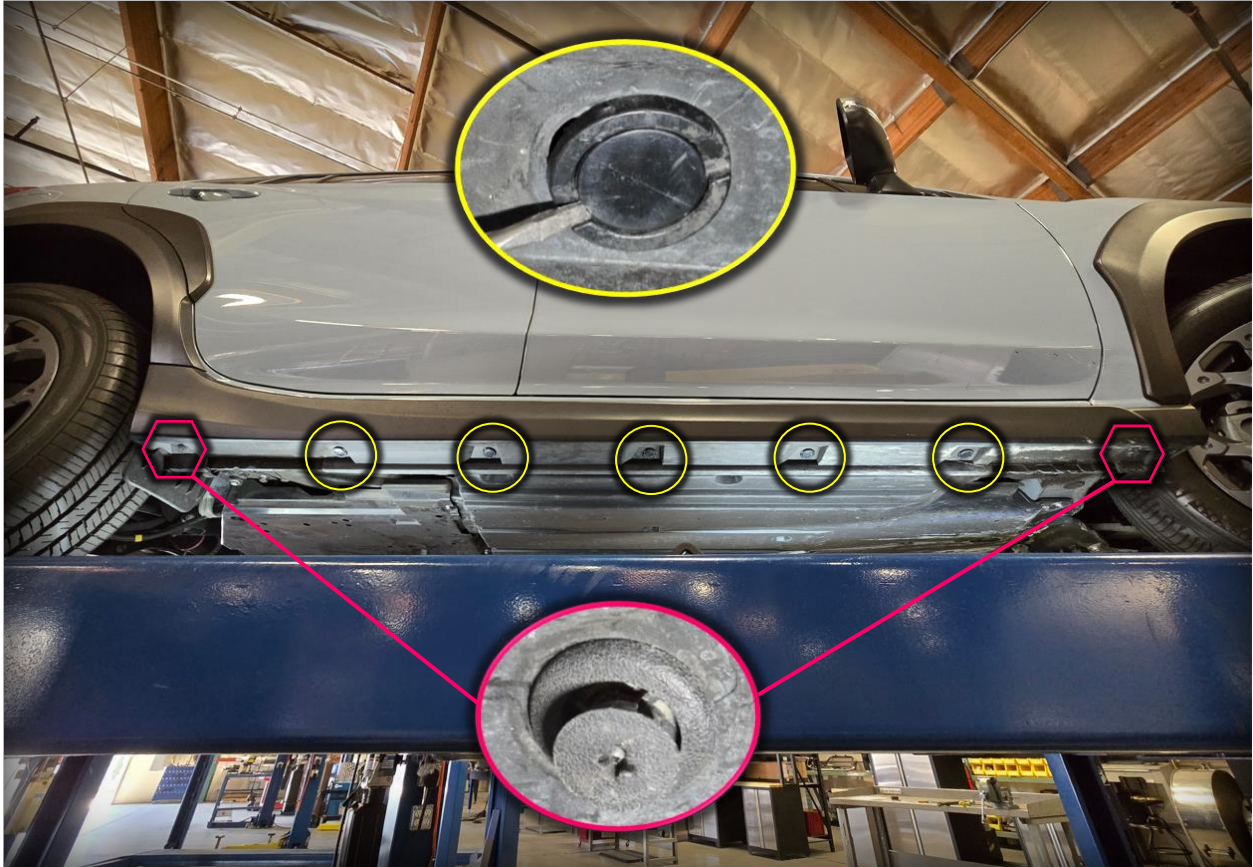

4. Pull cladding away from the body starting from the top rear.





5. Next, install the rivet nuts. The (9) M6 rivet nuts will go on the top vertical portion of the rocker.

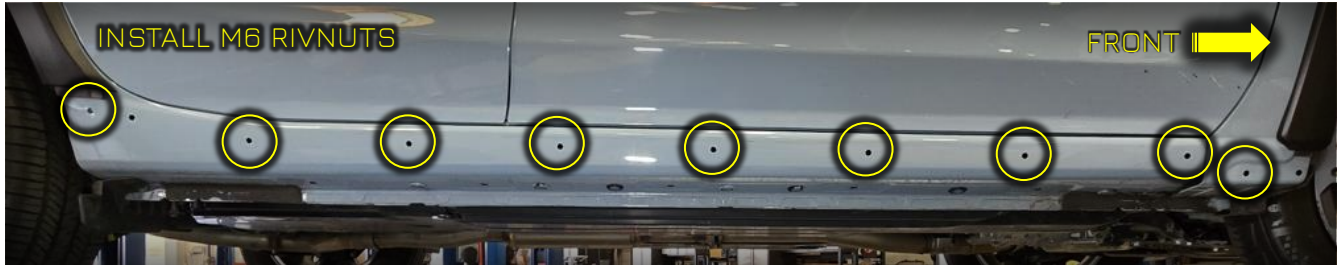

Install the (5) M8 rivet nuts on the bottom section of the panel.





Important Note:

Installing the rivet nuts is by far the trickiest part of this installation. Professional installation is highly recommended. If installing rivet nuts for the first time, purchasing a rivet nut setting tool is recommended. (see below) They are reasonably priced and available at your local hardware store or Amazon.



Rivet Nut Setting Tool (not included)

Your kit does include a rivet nut tool that works great when used with care. If you decide to use our tool, follow the procedure below.

- a) Insert the rivet nut into the hole flush to the panel.
- b) Install the appropriately sized hex bolt and washer on the top end of the tool. Grease/oil the surface where the head and washer meet.
- c) Install the star lock washer onto the bolt at the bottom of the tool. The star washer has a smooth side and a sharp side. Make sure the sharp side is facing the rivet nut. **Grease/oil the threads of the bolt.**
- d) Thread the bolt into the rivet nut, sandwiching the star washer. Once everything is finger tight, use a **10mm** or **13mm** socket and torque wrench to tighten the bolt while holding the tool stationary. The bolt should spin while rivet nut forms in place.
- e) Tighten until you reach **6 ft-lbs** for the **6mm** bolts and **8 ft-lbs** for the **8mm** bolts.
- f) Unscrew the bolt and move on to the next. Your kit includes a pair of each size bolt so you can use one bolt to set the rivet nuts for the driver side and one for the passenger side.

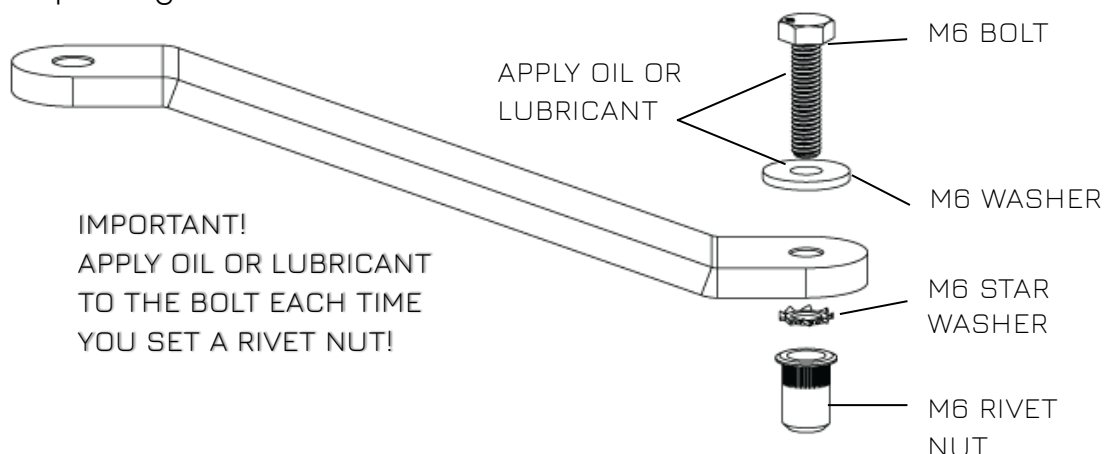



6. Install the Slider onto the car. Start by attaching the bottom with the M8 button heads (item #4) with the M8 washers (item #9) loosely. These panels can be heavy, so it helps to have another person hold one end when installing.

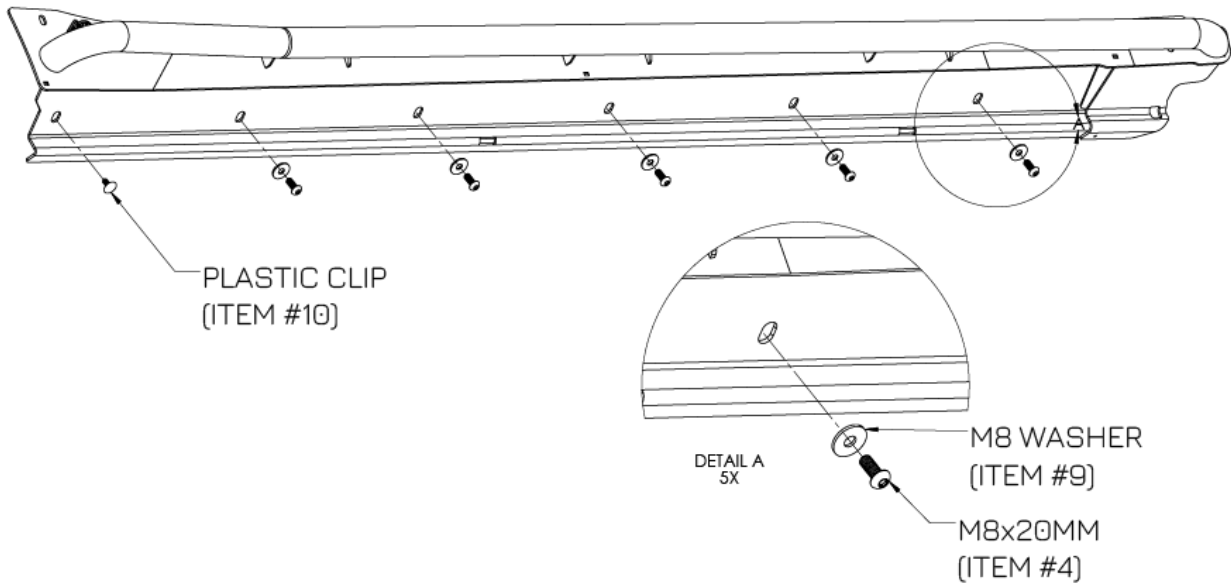

The OEM rear rubber flap will reside between the body and the step panel. Install the provided push retainer clip (item #10) into the last hole.



- Next, start attaching the top panel with the M6 button heads (item #3) and M6 washers (item #8). There is a special M6 hex bolt (item #5) that goes in the furthest forward mounting hole. It is a little challenging getting it in between the tube and the plate but be patient and it will install. Remember to keep all bolts loose to make it easier to start all of the fasteners.

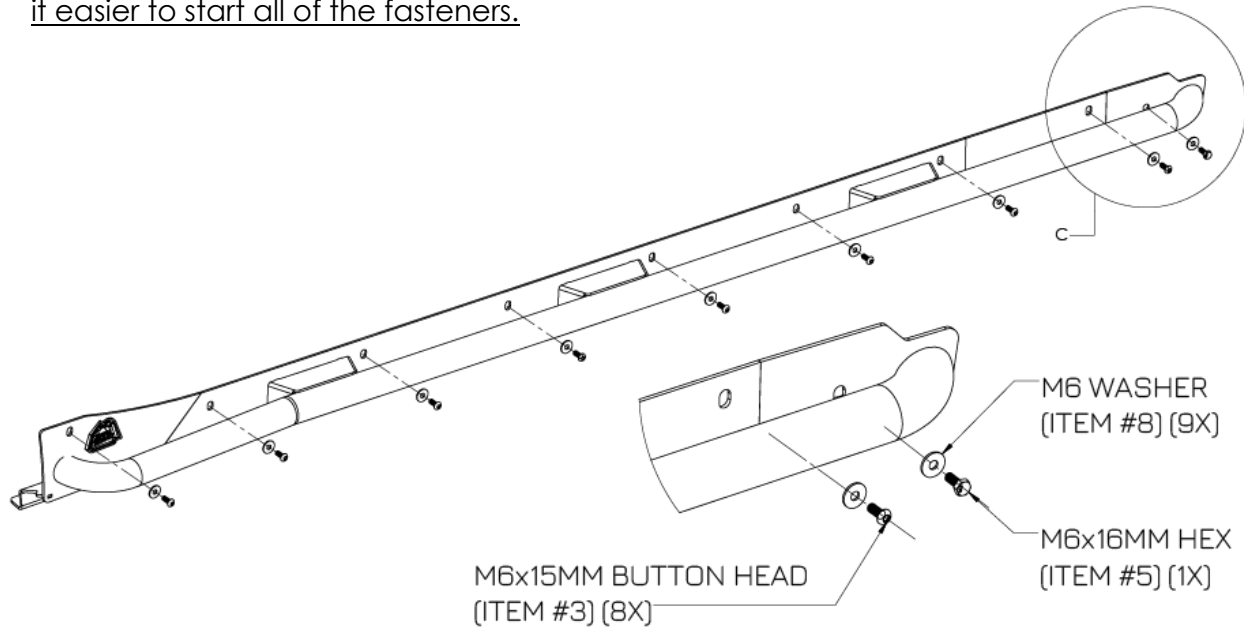

- Once all the bolts are started, snug all of the hardware before final tightening. Tighten **M8 bolts (12 ft-lbs)** and **M6 bolts (7 in · lbs)**.
- Reinstall the front screw-in clips in the wheel well.





10. Repeat on the other side and you are finished with the Terra Guard Slider install.





advanced FLOW engineering, inc.