

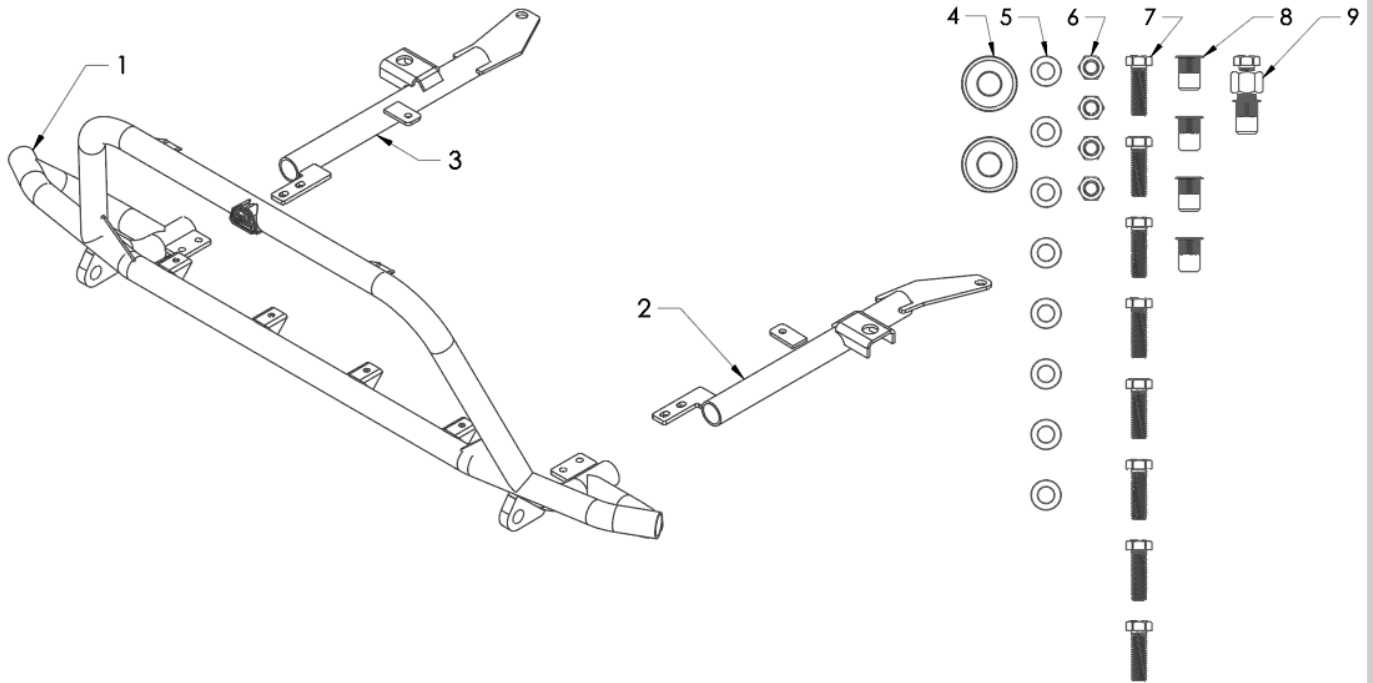

79-27007
aFe Power Terra Guard Bumper w/o Winch
Subaru Outback 10-14 BR Platform



Item	Description	P/N	Qty
1	Bumper, Front: BR 10-14 w/o Winch	05-61461	1
2	Mount, DS Bumper: BR 10-14	05-61455	1
3	Mount, PS Bumper: BR 10-14	05-61456	1
4	Washer: 1/2"	03-50494	2
5	Washer, 3/8" Flat	03-50230	8
6	Nut, 3/8-16	03-50047	4
7	Screw, 3/8-16 x 1-1/4 Hex Flange Head	03-50427	8
8	Rivet, Nut Open End: 3/8-16 Interior Thread	03-50569	4
9	Tool: Rivet Nut Installation	00P-0A1202-A	1



79-27010 aFe Power Terra Guard Bumper w/ Winch Subaru Outback 10-14 BR Platform

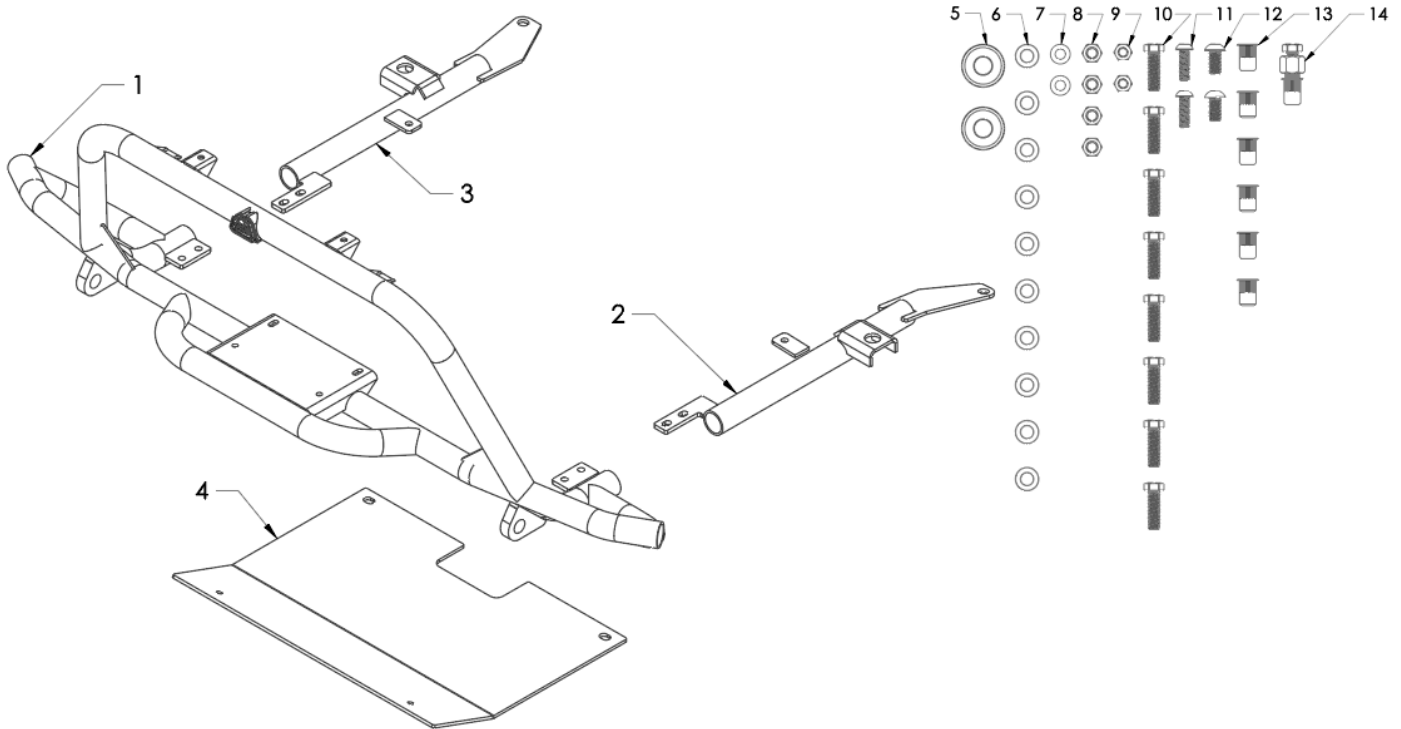

Item	Description	P/N	Qty
1	Bumper, Front: BR 10-14	05-61458	1
2	Mount, DS Bumper: BR 10-14	05-61459	1
3	Mount, PS Bumper: BR 10-14	05-61460	1
4	Skid Plate, 10-14 Subaru Outback	05-61376	1
5	Washer: 1/2"	03-50494	2
6	Washer, 3/8" Flat	03-50230	10
7	Washer, M8 x 16mm Flat	03-50159	2
8	Nut, 3/8-16	03-50047	4
9	Nut, M8	03-50244	2
10	Screw, 3/8-16 x 1-1/4 Hex Flange Head	03-50427	8
11	Screw, M8 x 25mm Button Head	03-50111	2
12	Screw, 3/8-16 x 1-1/4" Button Head	03-50827	2
13	Rivet, Nut Open End: 3/8-16 Interior Thread	03-50569	6
14	Tool: Rivet Nut Installation	00P-0A1202-A	1



- Please read the entire instruction manual before proceeding.
- Ensure all components listed are present.
- For technical support please call 951-493-7185.
- Ensure you have all necessary tools before proceeding.
- Retain factory parts for future use.

Recommended Tools & Equipment:

- Panel removal tool. Floor ramps or 4-post lift.

Warranty Information available at <https://afepower.com/contact#warranty>

Procedure:

1. This installation can be done with the vehicle on the ground. But, for an easier installation, drive the vehicle onto floor ramps or 4-post rack.





2. Install the (x4) Rivet Nuts for 79-27007 in the outer 4 subframe holes, for 79-27010 install the (x6) Rivet Nuts using the Rivet Nut Installation tool.

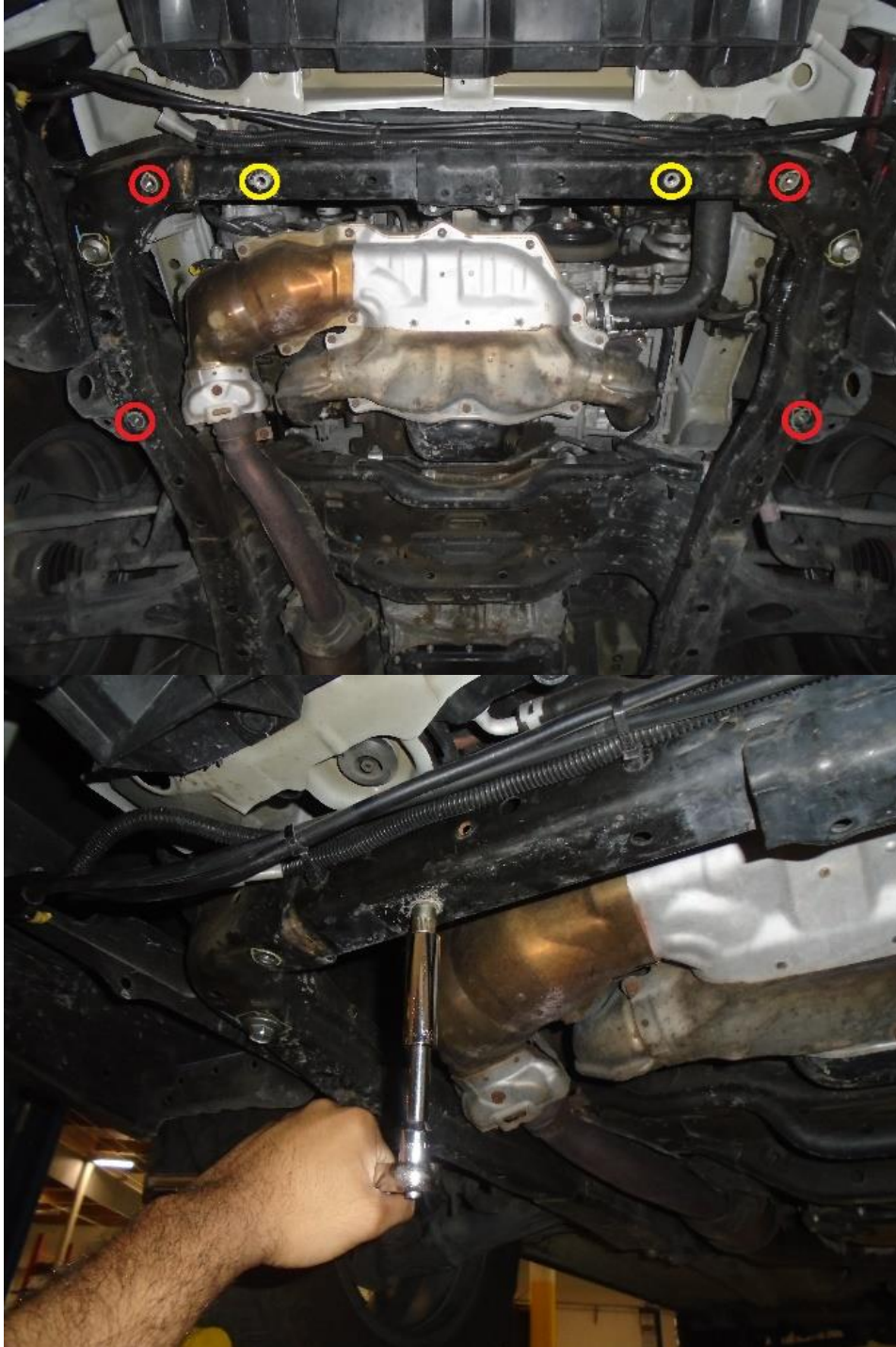



3. Remove the (2) Subframe Bolts from the vehicle.





4. Install the Driver Side Bumper Mount using the (1) $\frac{1}{2}$ " Washer, (2) $\frac{3}{8}$ " Flange Head Bolts, and the (2) $\frac{3}{8}$ " Washers. Make sure the $\frac{1}{2}$ " Washer is placed in between the Subframe and the Driver Side Bumper Mount. Leave hardware loose.





5. Install the Passenger Side Bumper Mount using the (1) $\frac{1}{2}$ " Washer, (2) $\frac{3}{8}$ " Flange Head Bolts, and the (2) $\frac{3}{8}$ " Washers. Make sure the $\frac{1}{2}$ " Washer is placed in between the Subframe and the Driver Side Bumper Mount. Leave hardware loose.

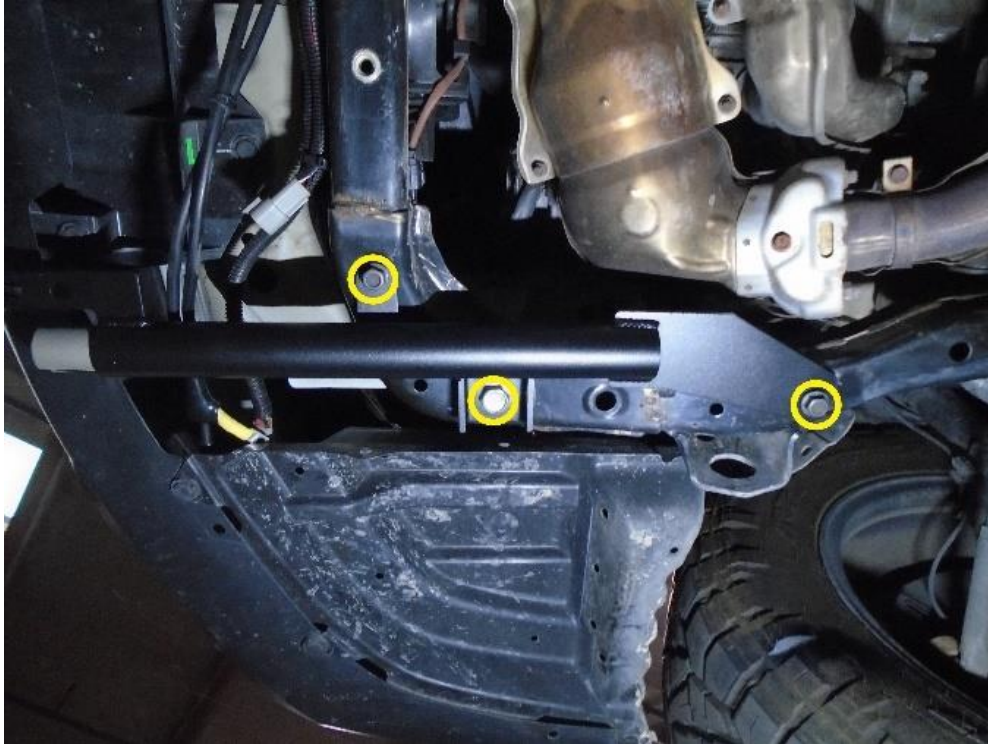



6. Install the Front Bumper using the (4) 3/8" Flange Head Bolt, (4) 3/8" Washers, and (4) 3/8" Nuts. Once the Front Bumper is Installed, tighten down all the hardware.





7. If installing 79-27007 the installation is complete. If installing 79-27010 with the winch proceed to install the Skid Plate using (2) 3/8 Button Head Bolt, (2) 3/8 Washers, (2) M8 Button Head Bolts, (2) M8 Washers and (2) M8 Nuts.



advanced FLOW engineering, inc.