

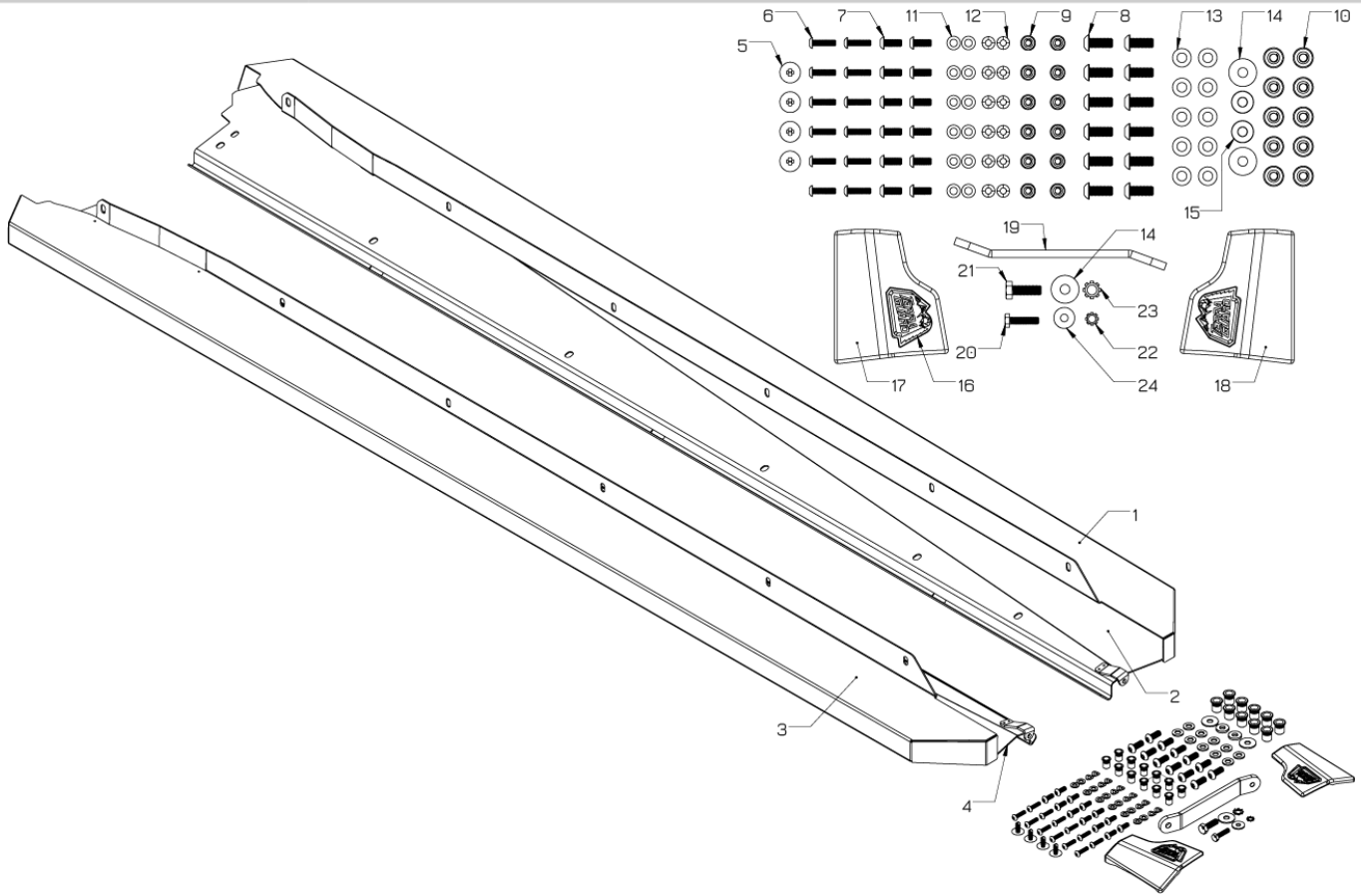

79-27005

aFe Power Terra Guard Trail Steps Subaru Outback 15-19 BS Platform



Item	Description	P/N	Qty
1	Panel, Top RT Trail Step, BS Outback	05-61483	1
2	Panel, Bottom RT Trail Step, BS Outback	05-61484	1
3	Panel, Top LF Trail Step, BS Outback	05-61485	1
4	Panel, Bottom LF Trail Step, BS Outback	05-61486	1
5	Retainer Clip, Christmas Tree Style: 9/32" Hole	03-50616	4
6	Screw, Btn Hd Socket: M5x.8x20, SS Black	03-50797	12
7	Screw, Btn Hd Socket: M6x1x15, SS Black	03-50795	12
8	Screw, Btn Hd Socket: M8x1.25x20, SS Black	03-50796	12
9	Rivet, Nut: M6	03-50799	12
10	Rivet, Nut: M8	03-50798	12
11	Washer, M6 (12mm OD x 6.4mm ID)	03-50177	12
12	Washer, Wavy: M5	03-50805	12
13	Washer, Flat M8: 16mm OD S/S	03-50159	10
14	Washer, Flat: 24mm ODxM8 ID	03-50065	3
15	Aluminum spacer 3/4 x 5/16 x 1/8	03-50800	2
16	Emblem, Terra Guard: 304SS (0.5mm 3M)	06-00238	2
17	Cover, RT, 15-19 Outback	05-01751	1
18	Cover, LF, 15-19 Outback	05-01752	1
19	Tool, Rivnut M6/M8	03-50801	1
20	Screw, Hex Head: M6x1x25mm	03-50114	1
21	Screw, Hex Head: M8x1.25x25mm	03-50421	1
22	Washer, Ext Star Lock M6	03-50803	1
23	Washer, Ext Star Lock M8	03-50804	1
24	Washer, Flat: M6	03-50070	1



- Please read the entire instruction manual before proceeding.
- Ensure all components listed are present.
- For technical support please call 951-493-7185.
- Ensure you have all necessary tools before proceeding.
- Retain factory parts for future use.

Recommended Tools & Equipment:

- 3mm, 4mm, 5mm Allen Sockets. 10mm & 13mm Sockets. Panel removal tool. Floor ramps or 4-post lift.

Warranty Information available at <https://afepower.com/contact#warranty>

Procedure:

1. This installation can be done with the vehicle on the ground. But, for an easier installation, drive the vehicle onto floor ramps or 4-post rack. Steer the front wheels towards the side you are working on. This will allow more space to work on the inner fender area.

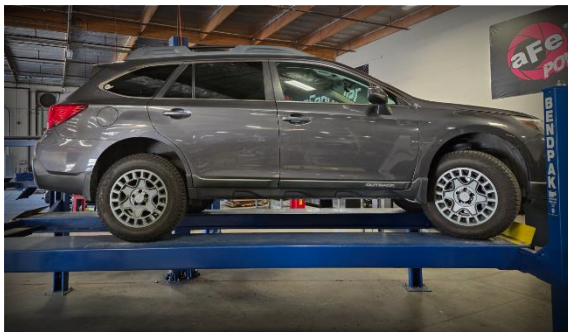

2. Locate the front splash guard area and remove the (2) pop clips and (3) screws just behind the front wheel.

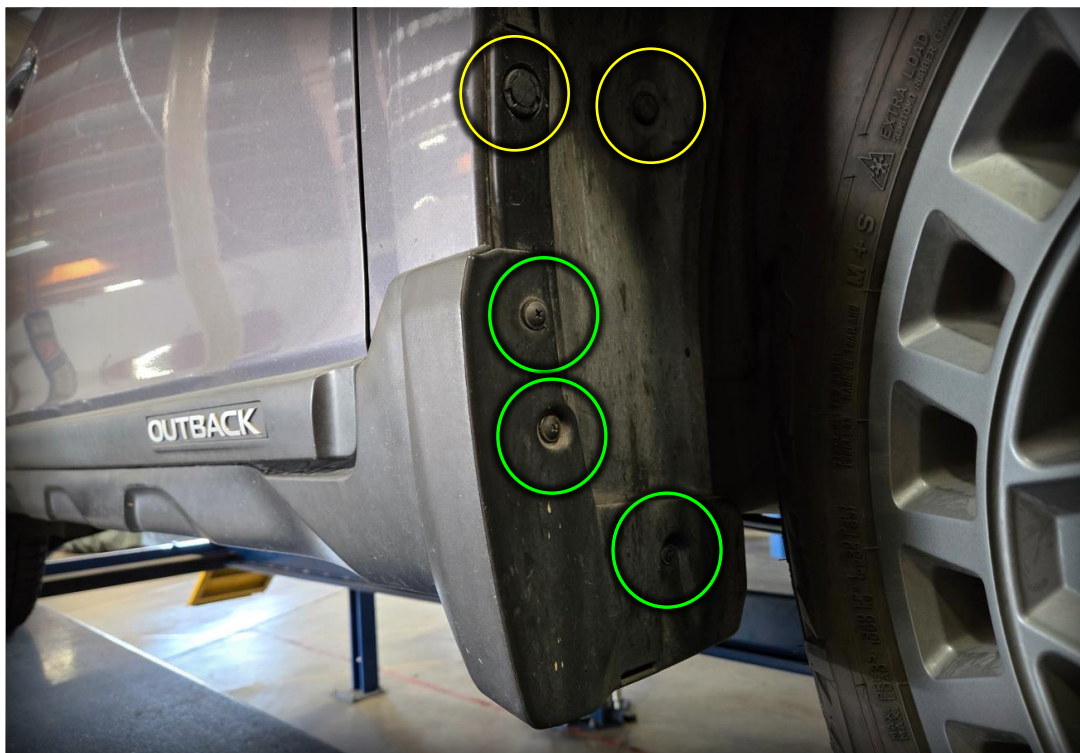



There is also a pop clip at the bottom of the splash guard that needs to be removed.



3. Remove the (6) pop clips at the bottom of the rocker panel.

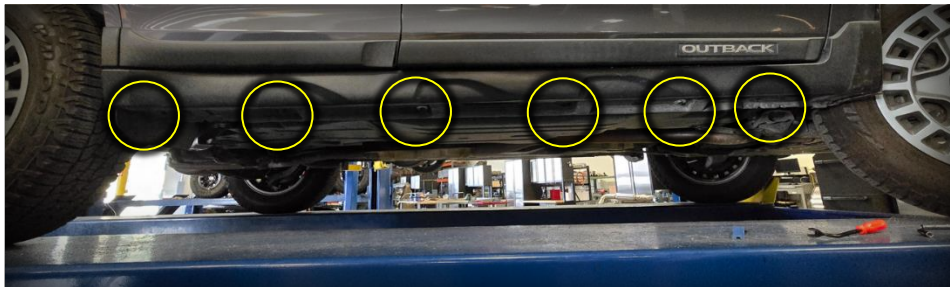



4. Pull cladding to separate the top portion of the panel away from the body.



5. Toward the front of the rocker cladding, at the bottom of the front fender, there (2) tricky push clips that need to be squeezed to release. Peel open the wheel well plastic to access the backside of these clips. You will need to pinch the two tangs on the clip to release. If you try to just pull on the plastic rocker cladding, you will end up separating the cladding from the clips, still leaving you with the chore of removing the clips from the fender.



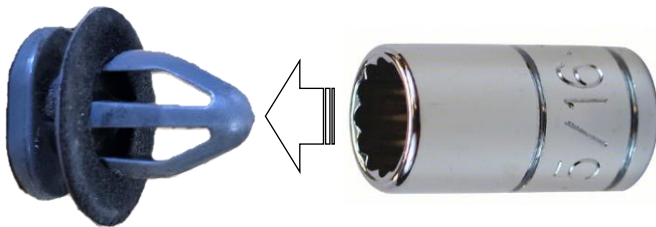
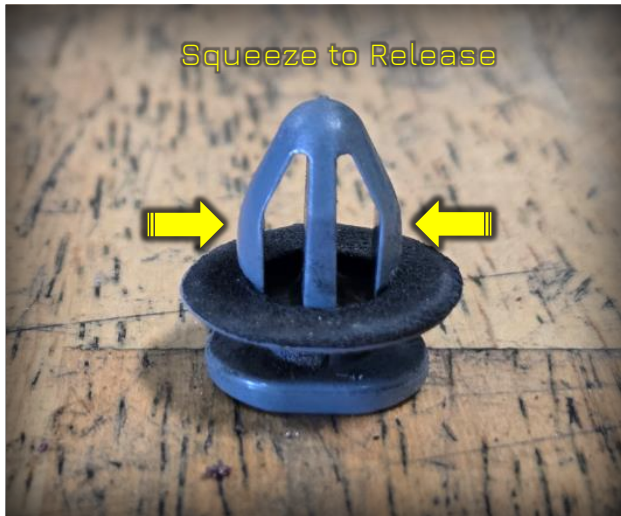

TIP:
If you have a 5/16", 12-point socket, you can sleeve it over the clip from the inside of the fender and release the clip.





6. There is a rubber flap near the rear of the rocker. Remove the pop clip to allow the rubber flap to pull away from the bottom.



7. (**Optional**) At this point you can choose to paint the lower portion of the rocker black to make the installation look seamless. Mask above the reference line indicated below. Scuff the paint with a Scotchbrite pad and clean with isopropyl alcohol. Truck bed liner works well for this application.



8. Next, install the rivet nuts. The (6) M6 rivet nuts will go on the top vertical portion of the rocker and the (6) M8 rivet nuts will install on the bottom section of the panel.

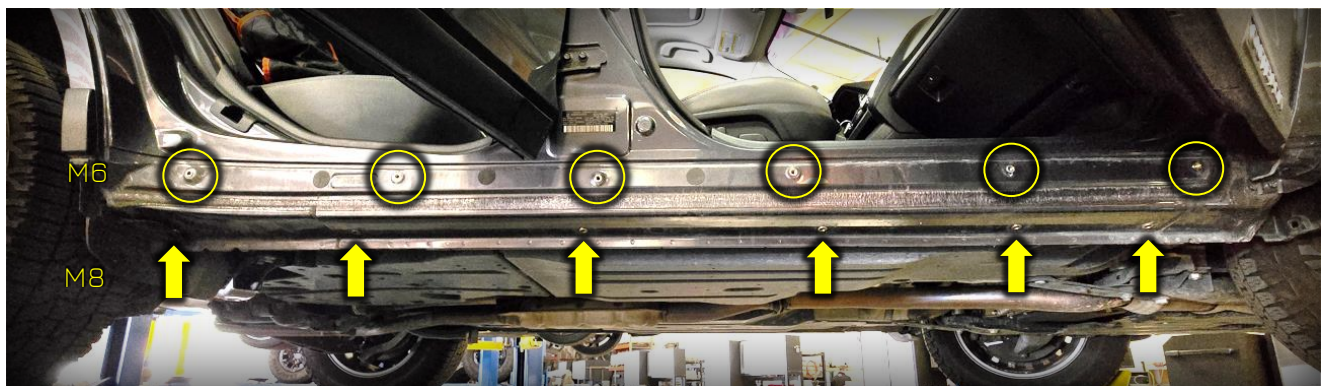



Important Note:

Installing the rivet nuts is by far the trickiest part of this installation. Professional installation is highly recommended. If installing rivet nuts for the first time, purchasing a rivet nut setting tool is recommended. (see below) They are reasonably priced and available at your local hardware store or Amazon.



Rivet Nut Setting Tool (not included)

Your kit does include a rivet nut tool that works great when used with care. If you decide to use our tool, follow the procedure below.

- a) Insert the rivet nut into the hole flush to the panel.
- b) Install the appropriately sized hex bolt and washer on the top end of the tool. Grease/oil the surface where the head and washer meet.
- c) Install the star lock washer onto the bolt at the bottom of the tool. The star washer has a smooth side and a sharp side. Make sure the sharp side is facing the rivet nut. **Grease/oil the threads of the bolt.**
- d) Thread the bolt into the rivet nut, sandwiching the star washer. Once everything is finger tight, use a **10mm** or **13mm** socket and torque wrench to tighten the bolt while holding the tool stationary. The bolt should spin while rivet nut forms in place.
- e) Tighten until you reach **6 ft-lbs** for the **6mm** bolts and **8 ft-lbs** for the **8mm** bolts.
- f) Unscrew the bolt and move on to the next. Your kit includes a pair of each size bolt so you can use one bolt to set the rivet nuts for the driver side and one for the passenger side.

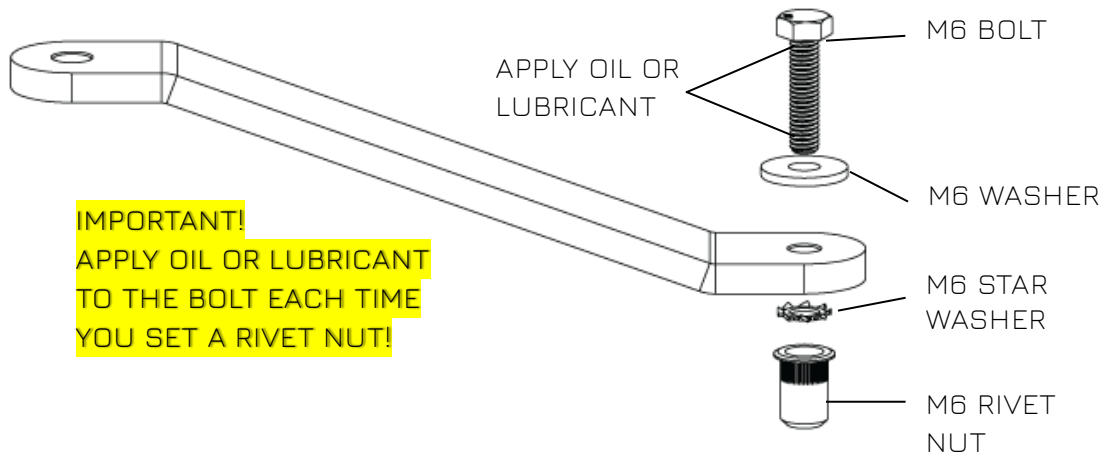

IMPORTANT!
APPLY OIL OR LUBRICANT
TO THE BOLT EACH TIME
YOU SET A RIVET NUT!





9. With the panels still loose and not installed on the vehicle, assemble the top and bottom panels together with the provided M5 button heads (item #6) and M5 wave washers (item #12). Start all by hand and leave them loose.

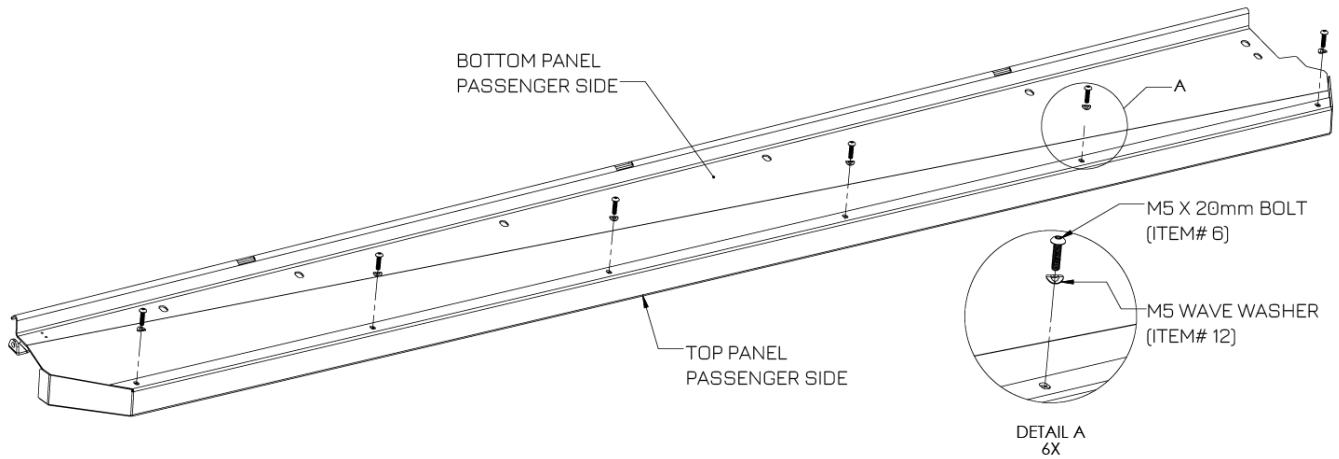



10. Install the step assembly onto the car. Start attaching the bottom with the M8 button heads (item #8) with the M8 washers (item #13) loosely. These panels can be heavy, so it helps to have another person hold one end when installing.

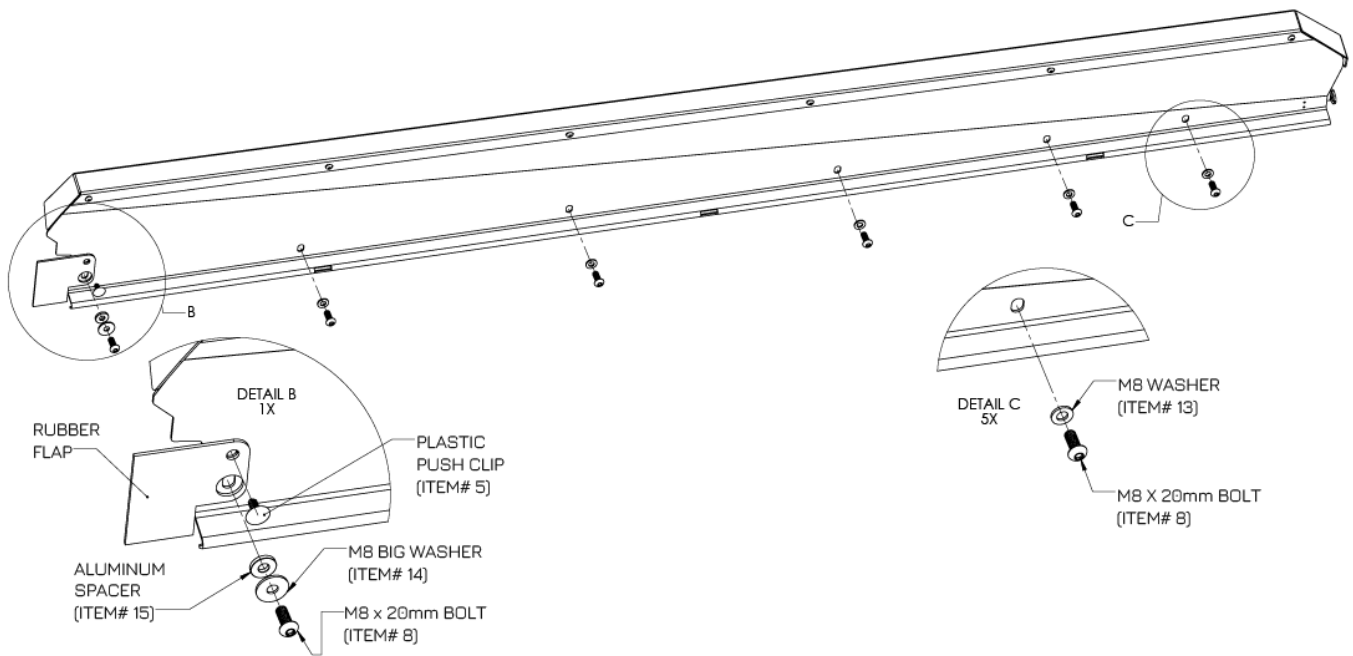



The OEM rear rubber flap will reside over the step panel so when you get to the last rearward bolt you will place the aluminum spacer (item #15) in the flap hole and larger M8 washer (item #14) to secure the rubber flap in place. Install the provided push retainer clip (item #5) into the smaller hole to further secure the rubber flap.

Next, start attaching the top panel with the M6 button heads (item #7) and M6 washers (item #11). Remember to keep all bolts loose to make it easier to start all of the fasteners.

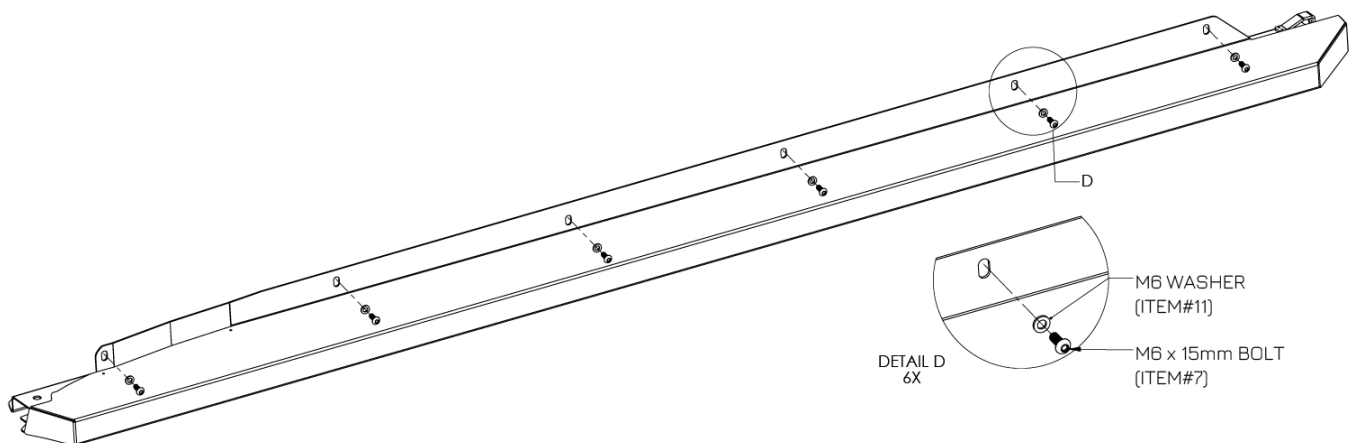



11. Once all of the bolts are started, we will tighten all of the fasteners. First, tighten the bottom panel **M8 bolts (12 ft-lbs)** and then work your way up to the **M5 bolts (4 ft-lbs)** that joins the two panels. Lastly, tighten the top **M6 bolts (7 ft-lbs)**. Tightening out of sequence may twist the step from its intended shape.
12. Install the front pop clip (ITEM# 5). Reinstall the (2) screws and (2) pop clips into the wheel well. (Note: aFe pop clip replaces the bottom screw)



13. Grab one of the front covers (ITEMS# 17, 18). Clean the area where the exposed holes are located. Peel the double sided backing and adhere the cover to the fender. Use the two dowel pins to locate the position of the cover.





14. Repeat on the other side and you are finished with the Terra Guard step install.





232 Granite St. Corona CA 92879 | aFePower.com | 951-493-7100



advanced FLOW engineering, inc.