

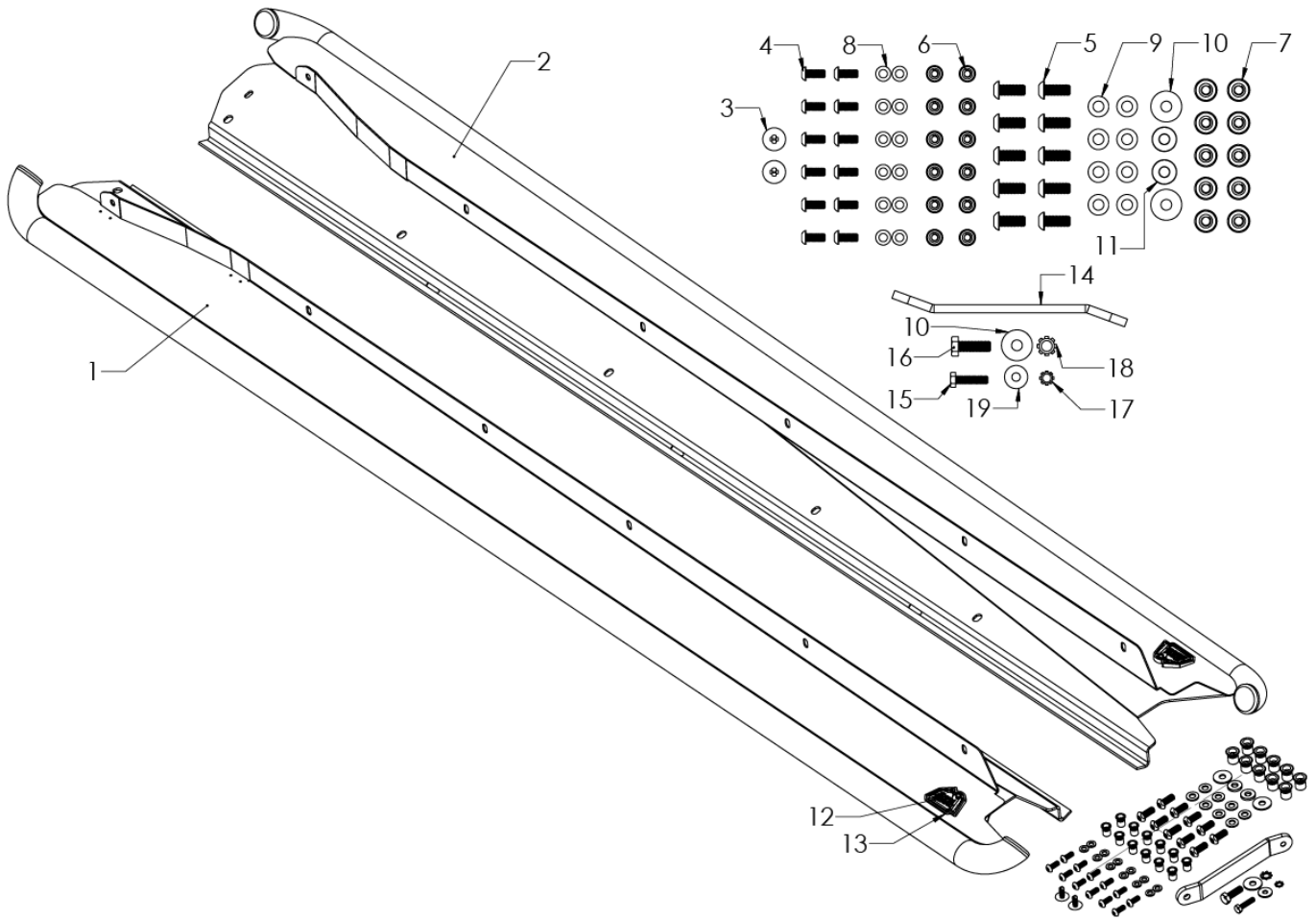

79-27003 aFe Power Terra Guard Off-Road Slider Subaru Outback 20+ BT Platform



Item	Description	P/N	Qty
1	Step, RT Slider Assembly, BT Outback	05-61401	1
2	Step, LF Slider Assembly, BT Outback	05-61402	1
3	Retainer Clip, Christmas Tree Style: 9/32" Hole	03-50616	2
4	Screw, Btn Hd Socket: M6x1x15, SS Black	03-50795	12
5	Screw, Btn Hd Socket: M8x1.25x20, SS Black	03-50796	10
6	Rivet, Nut: M6	03-50799	12
7	Rivet, Nut: M8	03-50798	10
8	Washer, M6 (12mm OD x 6.4mm ID)	03-50177	12
9	Washer, Flat M8: 16mm OD S/S	03-50159	8
10	Washer, Flat: 24mm ODxM8 ID	03-50065	3
11	Aluminum spacer 3/4 x 5/16 x 1/8	03-50800	2
12	Emblem, Terra Guard: 304SS (0.5mm 3M)	06-00238	2
13	Base, Flat Bottom, Terra Guard Badge	05-01748	2
14	Tool, Rivnut M6/M8	03-50801	1
15	Screw, Hex Head: M6x1x25mm	03-50114	1
16	Screw, Hex Head: M8x1.25x25mm	03-50421	1
17	Washer, Ext Star Lock M6	03-50803	1
18	Washer, Ext Star Lock M8	03-50804	1
19	Washer, Flat: M6	03-50070	1



- Please read the entire instruction manual before proceeding.
- Ensure all components listed are present.
- For technical support please call 951-493-7185.
- Ensure you have all necessary tools before proceeding.
- Retain factory parts for future use.

Recommended Tools & Equipment:

- 3mm, 4mm, 5mm Allen Sockets. 10mm & 13mm Sockets. Panel removal tool. Floor ramps or 4-post lift.

Warranty Information available at <https://afepower.com/contact#warranty>

Procedure:

1. This installation can be done with the vehicle on the ground. But, for an easier installation, drive the vehicle onto floor ramps or 4-post rack.



2. Locate the side plastic rocker panel. Remove the (2) pop clips just behind the front wheel. If your vehicle is equipped with front mud guards, you will need to remove them.

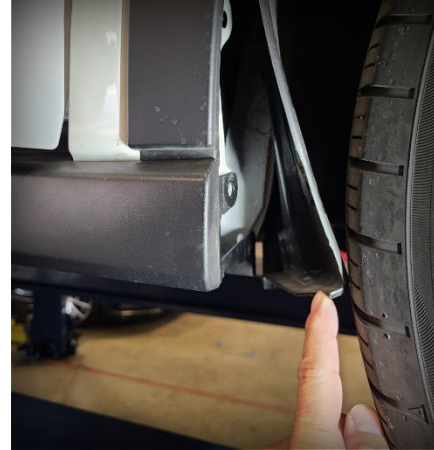

3. Remove the (6) pop clips at the bottom of the rocker panel.





4. Use a panel removal pry tool to separate the top portion of the panel away from the body. Panel should be free from the car.



5. There is a rubber flap near the rear of the rocker. Remove the pop clip to allow the rubber flap to pull away from the bottom.



6. **(Optional)** At this point you can choose to paint the lower portion of the rocker black to make the installation look seamless. Mask above the reference line indicated below. Scuff the paint with a Scotchbrite pad and clean with isopropyl alcohol. Truck bed liner works well for this application.





- Next, install the rivet nuts. The (6) M6 rivet nuts will go on the top vertical portion of the rocker and the (5) M8 rivet nuts will install on the bottom section of the panel.

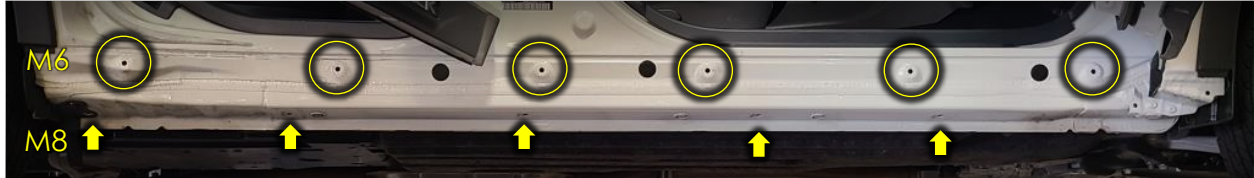

Your kit includes a rivet nut tool that allows for easy installation. Simply insert the rivet nut into the hole flush to the panel. Next install the appropriately sized bolt and washer on the top end of the tool and install the star lock washer at the bottom of the tool. Thread the bolt into the rivet nut, sandwiching the star washer. Once everything is finger tight, use a 10mm or 13mm socket to tighten the bolt while holding the tool stationary. The bolt should spin while rivet nut forms in place. Once you feel a noticeable increase in resistance the rivet should be formed completely tight onto the sheet metal. Unscrew the bolt and move on to the next.

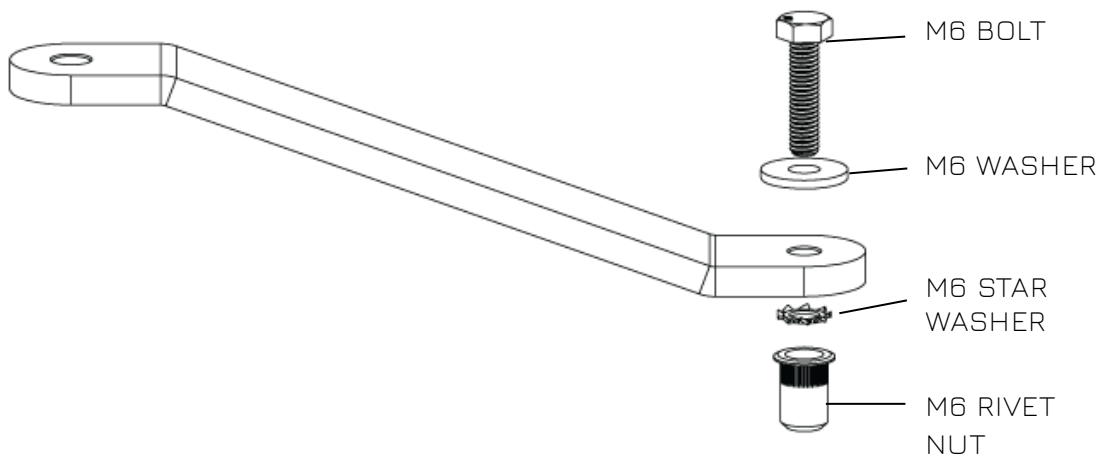



8. Install the Slider onto the car. Start attaching the bottom with the M8 button heads (item #5) with the M8 washers (item #9) loosely. These panels can be heavy, so it helps to have another person hold one end when installing.

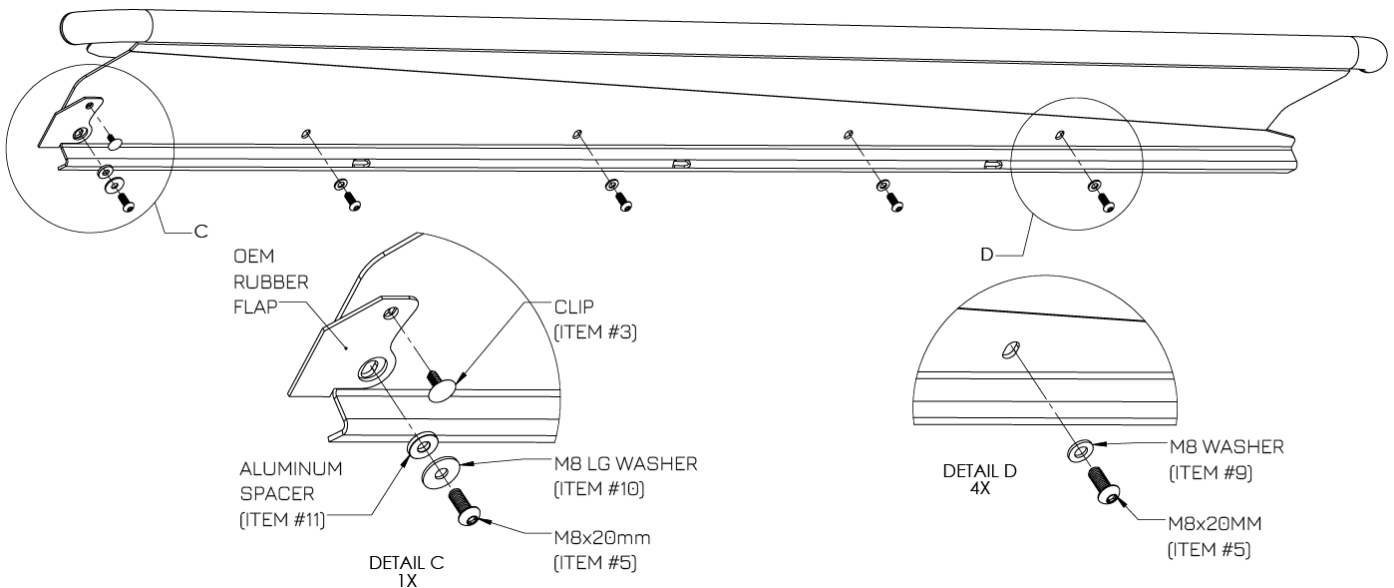

The OEM rear rubber flap will reside over the step panel so when you get to the last rearward bolt you will place the aluminum spacer (item #11) in the flap hole and larger M8 washer (item #10) to secure the rubber flap in place. Install the provided push retainer clip (item #3) into the smaller hole to further secure the rubber flap.



Next, start attaching the top panel with the M6 button heads (item #4) and M6 washers (item #8). Remember to keep all bolts loose to make it easier to start all of the fasteners.

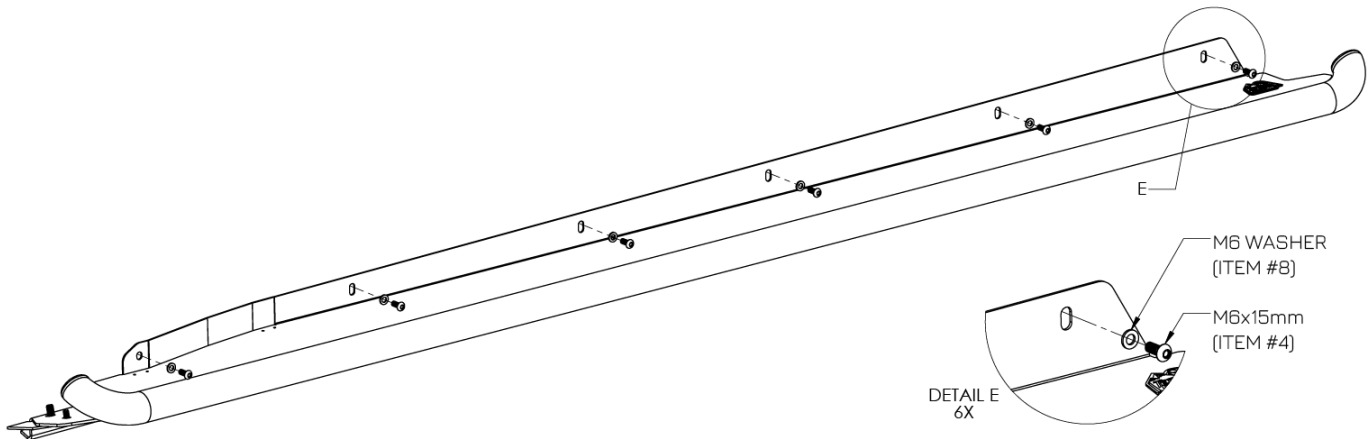

9. Once all of the bolts are started, we will tighten all of the fasteners. First, tighten the bottom panel **M8 bolts (240 in · lbs)** and then work your way up to the top **M6 bolts (80 in · lbs)**. Tightening out of sequence may twist the step from its intended shape.



Left Intentionally Blank



advanced FLOW engineering, inc.