

***advanced FLOW engineering***

D.A.S.+ (Dynamic Air Scoop with OER Air filter)

**Instruction Manual** P/N: 55-11002D

Make: Ford

Model: Ranger

Year: 2019-2023

Engine: I4-2.3L (t)

Make: Ford

Model: Ranger

Year: 2019-2023

Engine: I4-2.0L(td) Bi-Turbo



- Please read the entire instruction manual before proceeding.
- Ensure all components listed are present.
- For technical support please call 951-493-7185.
- Ensure you have all necessary tools before proceeding.
- Do not attempt to work on your vehicle when the engine is hot.
- Retain factory parts for future use.

Label	Qty.	Description	Part Number
A	1	Scoop, Plastic (Black)	05-5413056B3
B	1	OER Air Filter, PDS	31-10294

**Installation will require the following tools:**

T-30 Torx Screwdriver

Warranty Information available at: <https://afepower.com/contact#warranty>

**Emissions Disclaimer:** This product is not currently CARB exempt and is not available for purchase in California or for use on any vehicle registered with the California Department of Motor Vehicles.

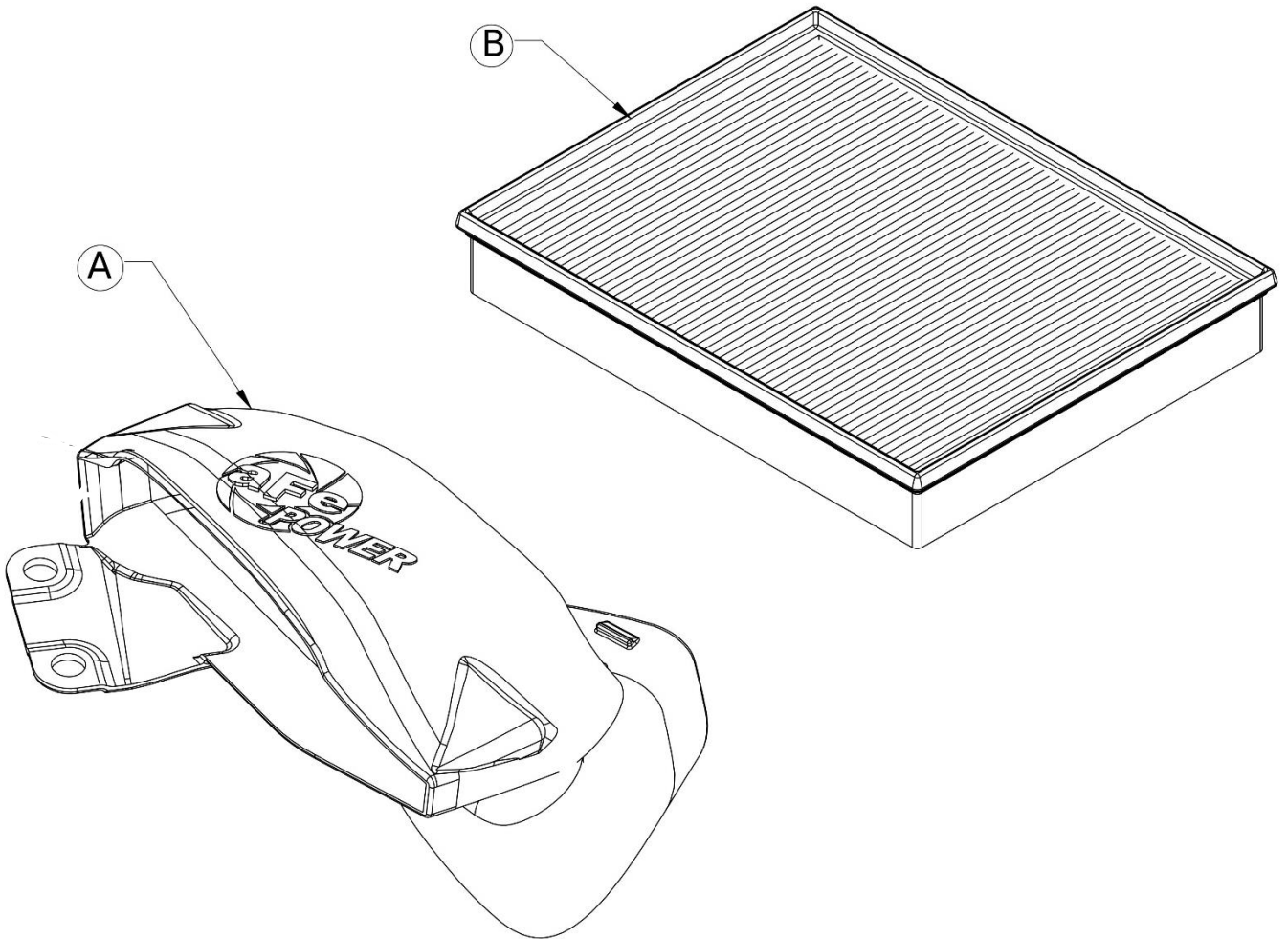

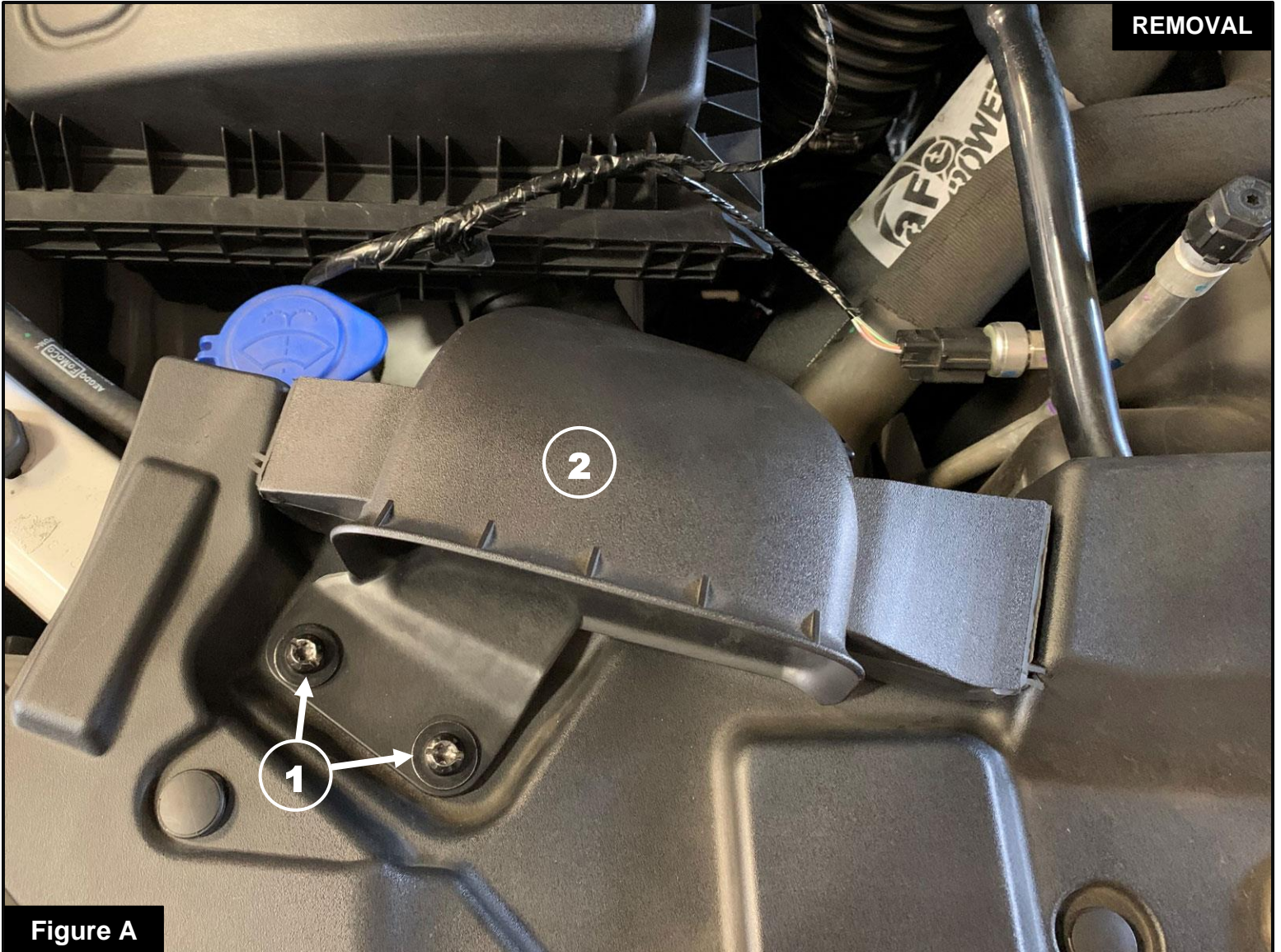
**Figure A****Refer to Figure A for Step 1**

Step 1: Using a T30 Torx drive, remove the two screws ① holding down the air scoop ②. Remove the scoop from the factory air intake.

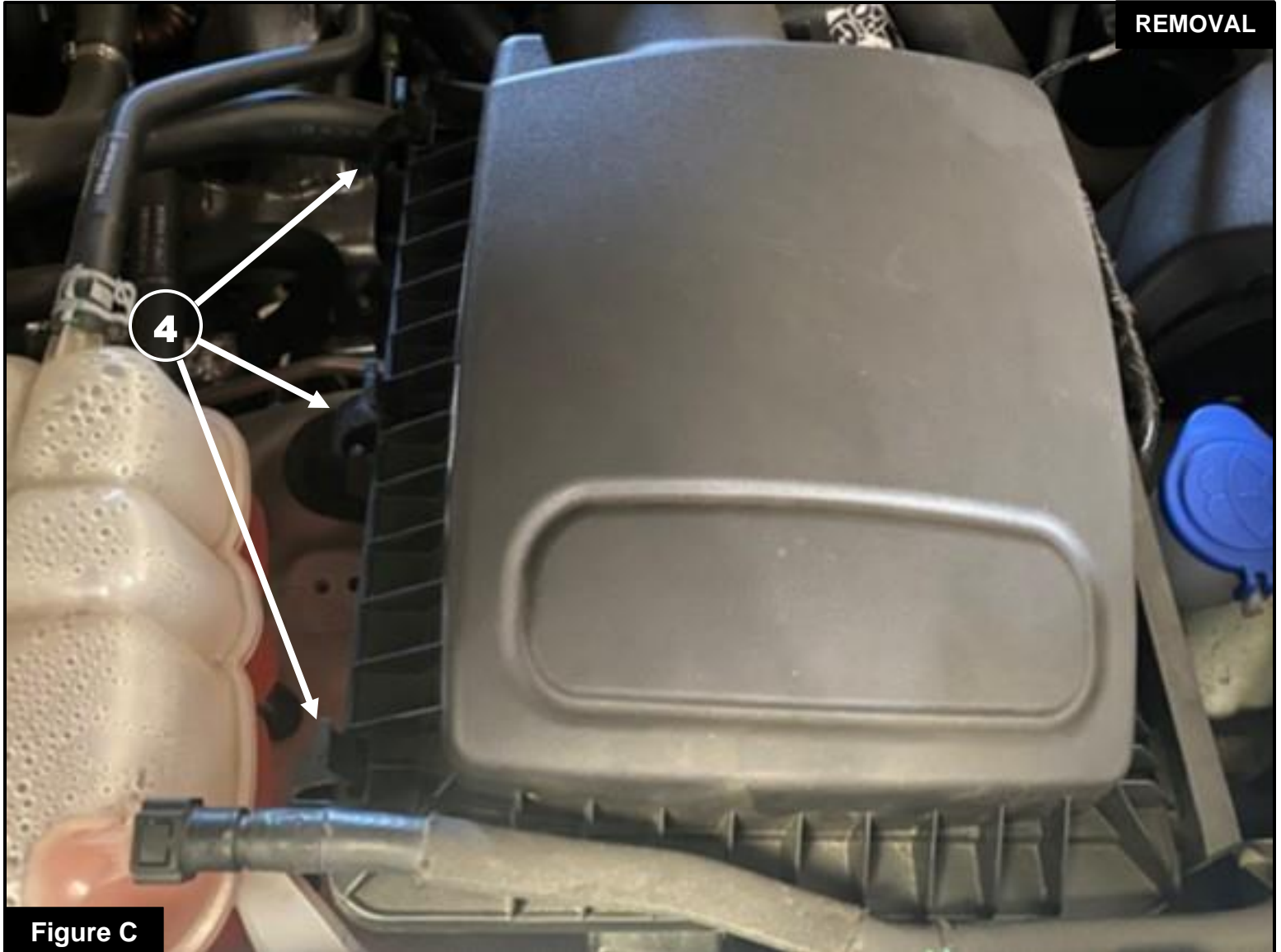

Figure B

**Refer to Figure B for Step 2**

Step 2: Install the aFe POWER scoop into the factory air intake and secure the scoop using the two screws

③ removed in Step 1.



**Refer to Figure C for Steps 3-4**

Step 3: Remove the factory air intake cover by releasing the clips (4) located in the back of the factory air intake. Remove the factory filter and install the aFe POWER OER filter. Close the factory air intake cover after installing new aFe POWER OER filter.

Step 4: The installation of the aFe POWER scoop and aFe POWER OER filter is complete. Thanks for choosing aFe POWER.

**NOTE: Check all screws are secure after 100-200 miles.**



Page left blank intentionally

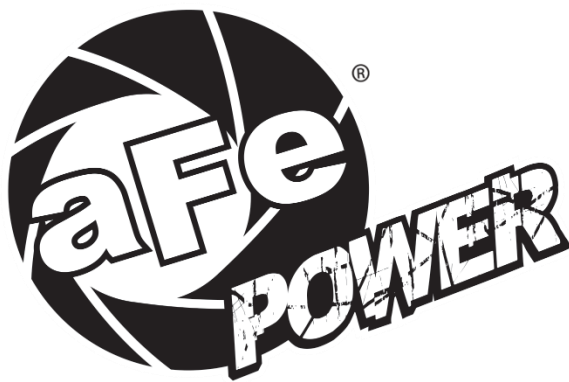

***advanced FLOW engineering, inc.***

Corona, CA 92879

<https://afepower.com/contact>