

# **GT** **MOMENTUM**

**advanced FLOW engineering** Momentum GT Stage-2 Cold Air Intake System

**Instruction Manual** P/N: 50-70080D / 50-70080R

Make: Jeep

Model: Wrangler Rubicon 392 (JL)

Year: 2021-2022

Engine: V8-6.4L



- Please read the entire instruction manual before proceeding.
  - Ensure all components listed are present.
- If you are missing any of the components, call customer support at 951-493-7185.
  - Ensure you have all necessary tools before proceeding.
- Do not attempt to work on your vehicle when the engine is hot.
  - Retain factory parts for future use.

Label	Qty.	UoM	Description	Part Number
A1	1	Ea	Air Filter (Pro DRY S)	21-91124
A2	1	Ea	Air Filter (Pro 5R)	24-91124
B	1	Ea	Tube	05-5070080B1
C	1	Ea	Housing	05-5070080B2
D	1	Ea	Coupling, Silicone Elbow Reducer	05-01682
E	1	Ea	Clamp, T-Bolt (3-9/16" – 3-7/8") SS	03-50498
F	1	Ea	Clamp, T-Bolt (4-5/16" – 4-5/8") SS	03-50499
G	1	Ea	Grommet, Rubber	03-50167
H	1	Ea	Fitting, Air Temp Sensor	05-01454
J	6	In	Hose, Silicone 3/4" ID	05-01475

**Installation will require the following tools:**

8mm nut driver, 10mm socket and wrench, 11mm deep socket or hollow shaft nut driver, pliers, and Flat-head screwdriver.

Warranty Information available at: <https://afepower.com/contact#warranty>

**Emissions Disclaimer:** This product is not currently CARB exempt and is not available for purchase in California or for use on any vehicle registered with the California Department of Motor Vehicles.

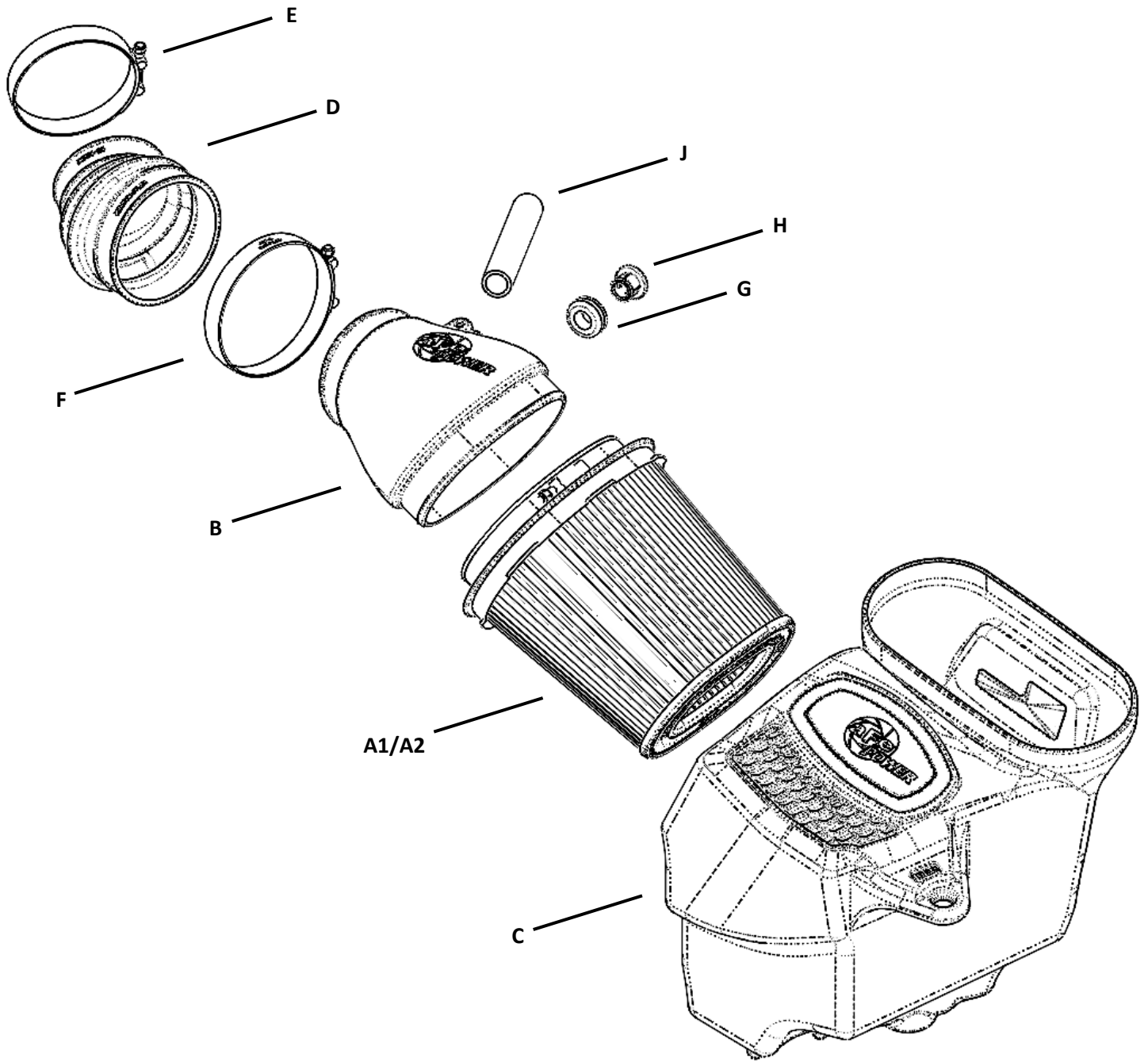

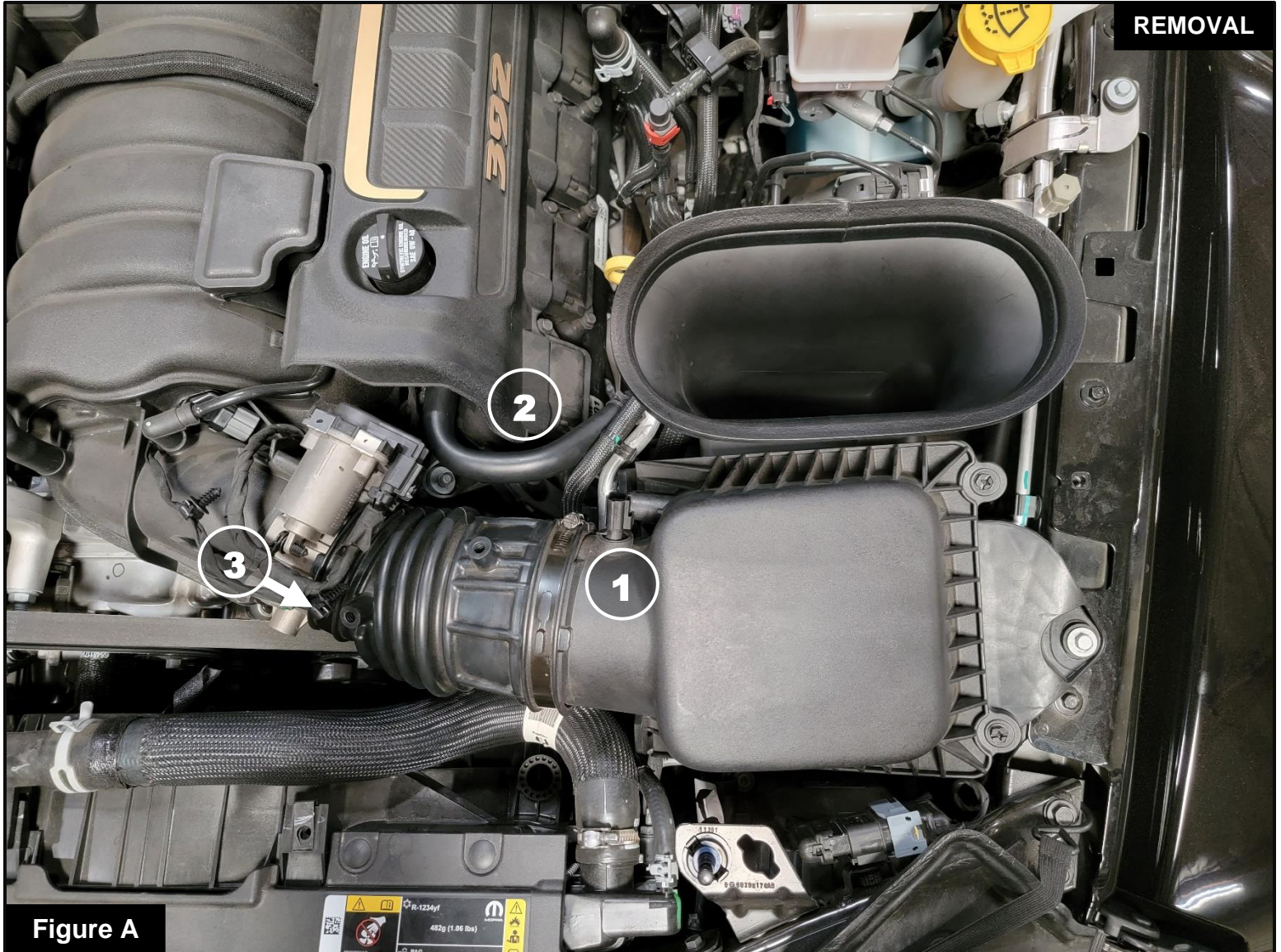

Figure A

**Refer to Figure A for Steps 1-4**

**Step 1:** Unclip the Intake Air Temperature (IAT) sensor harness from the IAT sensor on the tube ①.

Disconnect the two wire harness clips from the intake tube by pulling them out of the holes.

**Step 2:** Disconnect the Crank Case Vent (CCV) hose from the airbox using a pair of pliers to open the spring clamp. Tuck the hose out of the way as shown ②.

**Step 3:** Using an 8mm nut driver, loosen the clamp on the intake tube near the throttle body ③.

**Step 4:** Loosen the (2) two screws on the airbox and then remove the upper half of the airbox and intake tube from the vehicle.

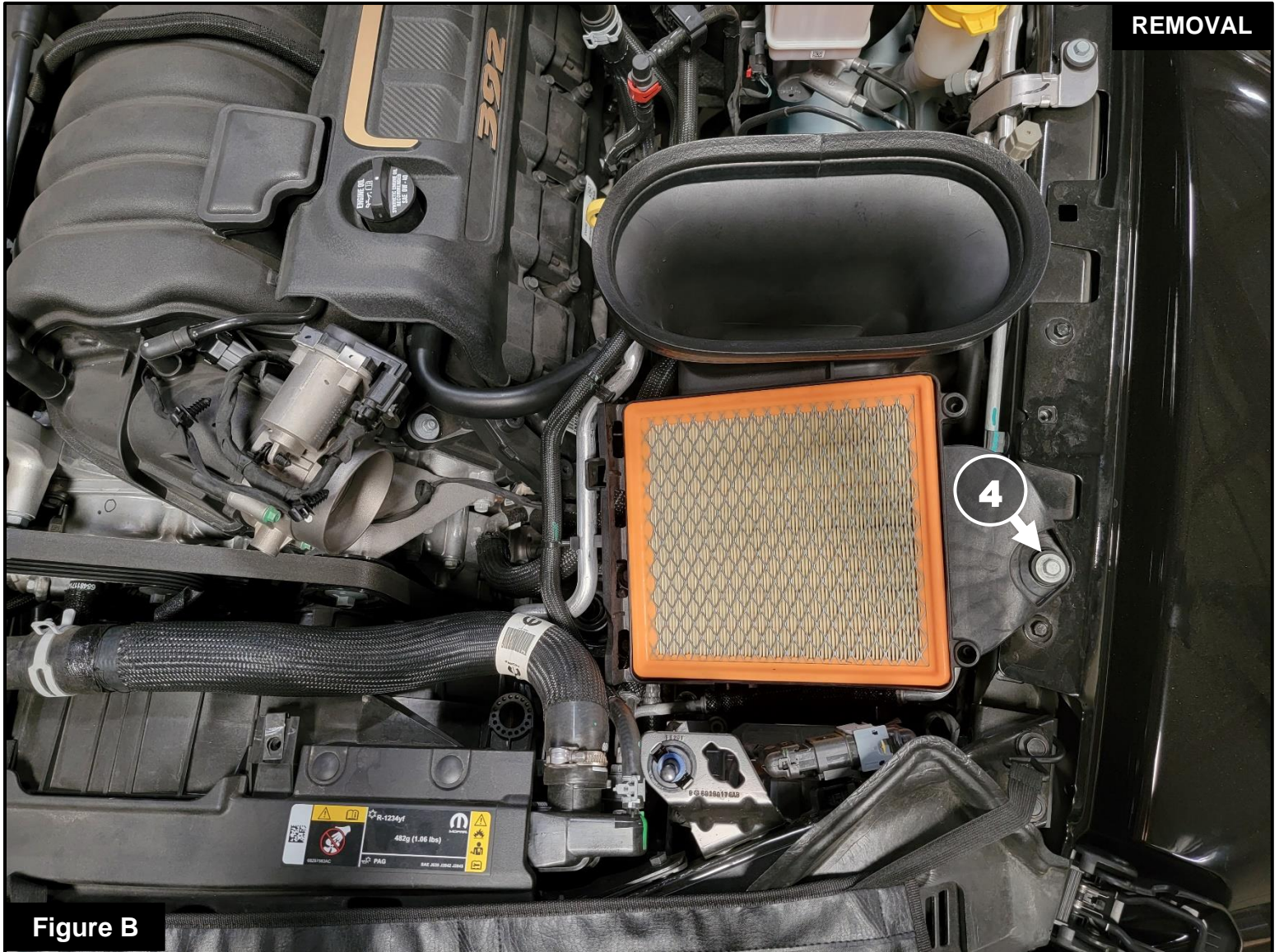

**Refer to Figure B for Steps 5-7**

**Step 5:** Remove the air filter from the airbox.

**Step 6:** Remove the screw that secures the airbox to the fender (4).

**Step 7:** Pull straight upward on the airbox to remove it from the vehicle. There are three grommets located on the bottom of the airbox securing it in place.



Figure C

**Refer to Figure C for Steps 8-10**

**Step 8:** Remove the metal sleeve and rubber grommet from the lower half of the factory airbox (5).

**Step 9:** Remove the duckbill drain from the bottom of the factory airbox (6).

**Step 10:** Remove the trim seal from the large air scoop on the factory airbox (7).

**Figure D****Refer to Figure D for Step 11**

**Step 11:** Remove the IAT sensor from the vehicle. Carefully lift the locking tab, twist the sensor a quarter turn counterclockwise, and then pull the IAT sensor out of the airbox (8).



### Refer to Figure E for Step 12

**Step 12:** Remove the CCV hose from the valve cover by pulling it forward. There are no clamps on this side of the hose (9).

**Note:** For easier viewing and better access, the beauty cover can be removed from the valve cover, however it is not necessary for this install.

**Figure F****Refer to Figure F for Steps 13-15**

**Step 13:** Reinstall the rubber grommet and metal sleeve, previously removed from the factory airbox, into the mounting tab on the new aFe POWER housing (10).

**Step 14:** Reinstall the duckbill drain into the hole on the bottom of the new aFe POWER housing (11).

**Step 15:** Reinstall the trim seal onto the scoop of the aFe POWER housing (12). Ensure the seal is pushed all the way onto the housing all the way around.

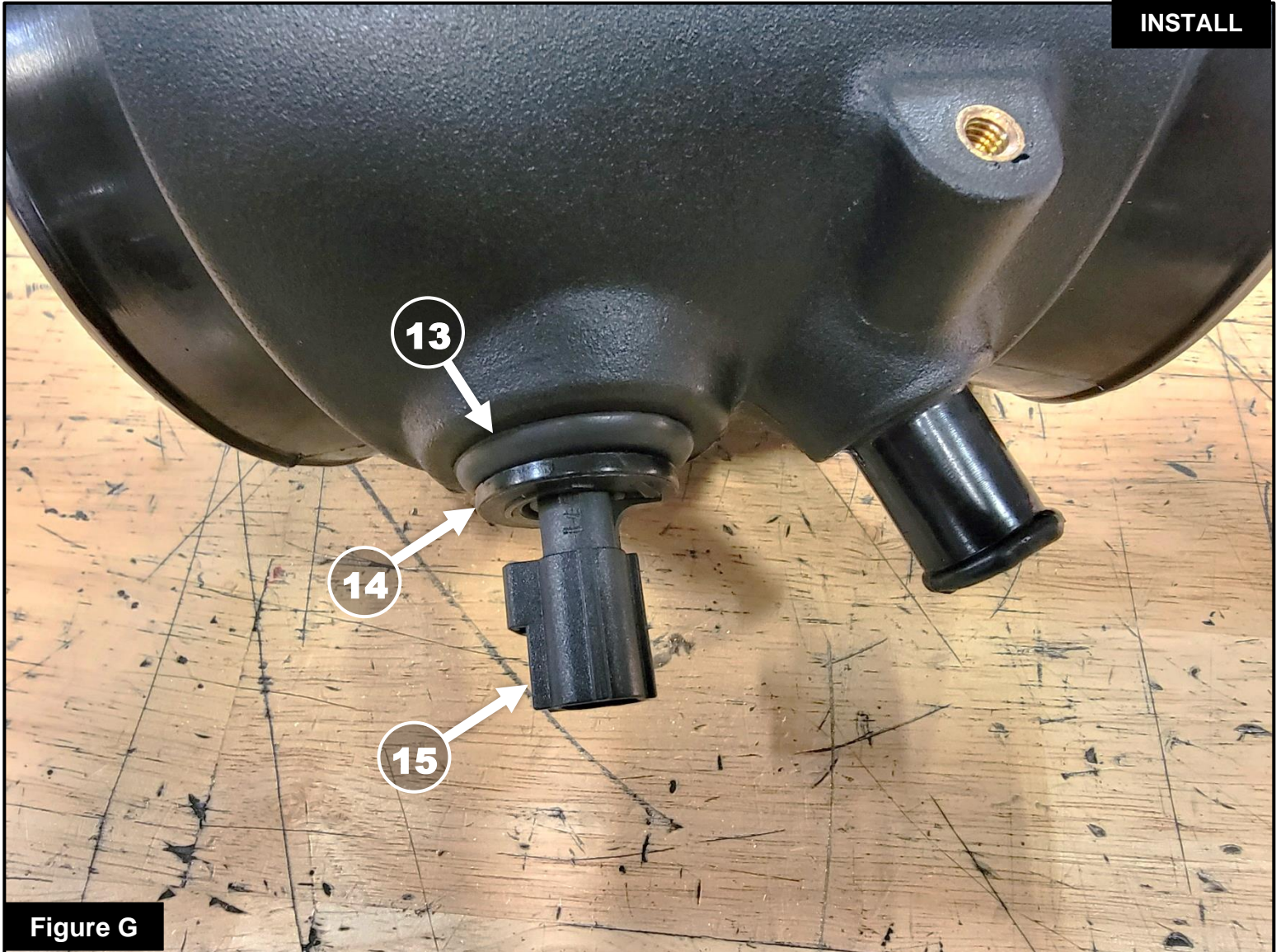
**Figure G****Refer to Figure G for Steps 16-18**

**Step 16:** Install the new rubber grommet into the aFe POWER intake tube as shown (13) .

**Step 17:** Install the new IAT fitting into the grommet and make sure that it's pushed in all the way (14) .

**Step 18:** Install the factory IAT sensor into the fitting by aligning the indexing tabs, inserting the sensor, and rotating it a quarter turn clockwise until the locking tab is engaged (15).

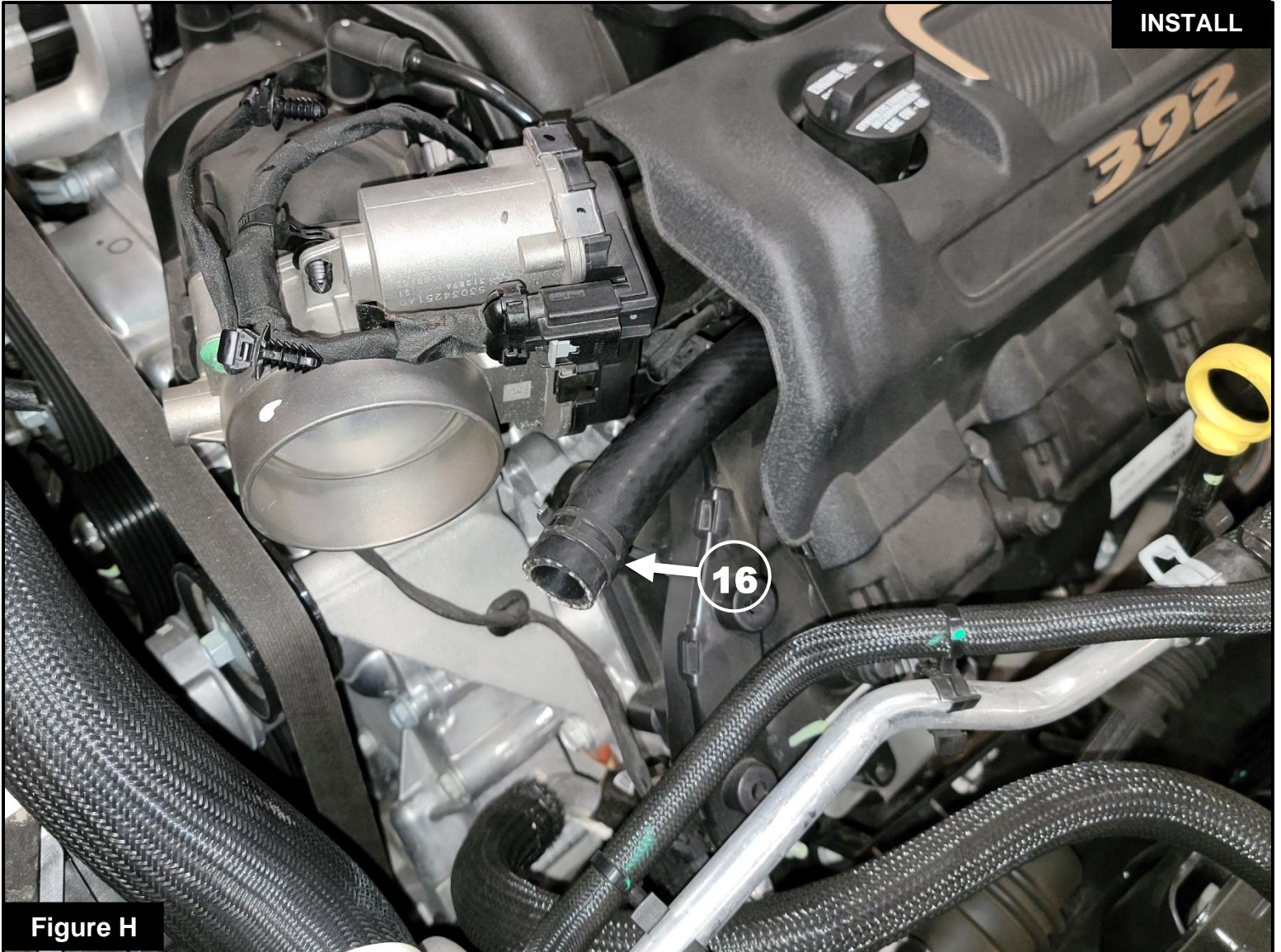
**Figure H****Refer to Figure H for Steps 19-20**

**Step 19:** Transfer the spring clamp over to the new silicone hose included in the kit ①⑥ .

**Step 20:** Install the new silicone hose onto the valve cover as shown.

**Figure I****Refer to Figure I for Step 21**

**Step 21:** Insert the new aFe POWER filter into the housing as shown. Ensure the locking tabs engage by slightly rotating the filter while pushing inward.

**Figure J****Refer to Figure J for Steps 22-23**

**Step 22:** Install the new aFe POWER housing and filter into the vehicle by first lining up the mounting pegs with the grommets and then pressing down firmly to lock the pegs into the grommets.

**Step 23:** When properly installed, the mounting tab near the fender should be at the same level as the fender.

**Note:** Do not install the mounting screw yet.

**Figure K****Refer to Figure K for Step 24**

**Step 24:** Preinstall the appropriate clamps onto the coupler and then install the coupler onto the tube as shown. Do not tighten any of the clamps at this time.

**Figure L****Refer to Figure L for Steps 25-27**

**Step 25:** Install the aFe POWER tube and coupler assembly into the vehicle by slipping the coupler onto the throttle body and then inserting the tube into the air filter.

**Step 26:** Align the coupler so that all of the end faces align properly and there is no gap between the coupler and its mating faces.

**Step 27:** Position the clamps on the coupler vertically as shown so that they are clear of any belts, cables, and hoses (17) .

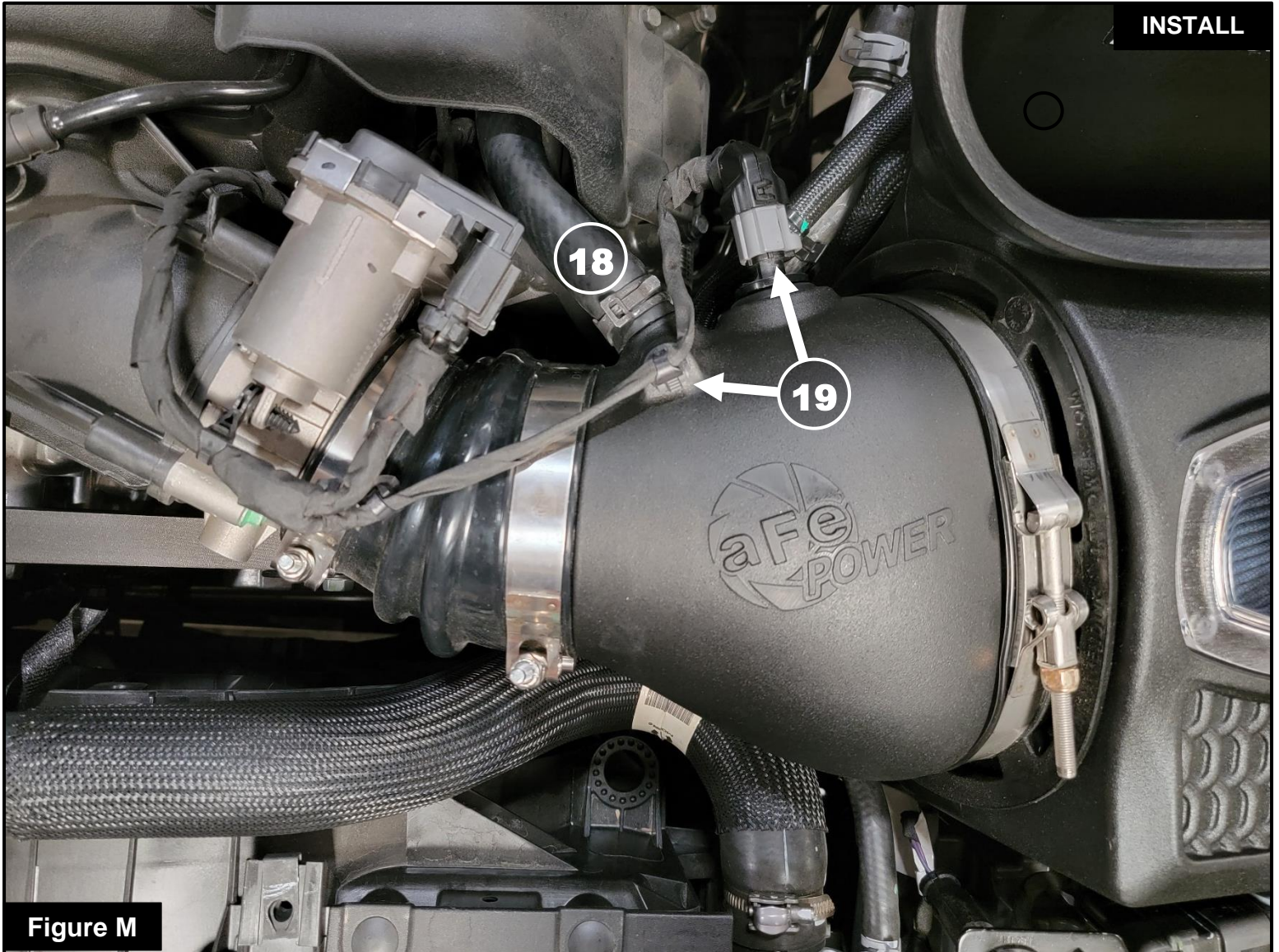

Figure M

**Refer to Figure M for Steps 28-29**

**Step 28:** Connect the CCV hose to the aFe POWER intake tube using pliers for the spring clamp (18).

**Step 29:** Connect the IAT sensor harness to the IAT sensor, and clip one of the tabs on the IAT harness into the threaded insert on the intake tube (19). The other clip can be removed or tucked out of the way.

**Figure N****Refer to Figure N for Steps 30-32**

**Step 30:** Reinstall the bolt using a 10mm socket and driver to secure the new aFe POWER housing to the fender ②0.

**Step 31:** Tighten all (3) three T-Bolt clamps at this time. Use caution not to overtighten these clamps and damage the plastic tube.

**Step 32:** Check all the components are tight and secure. Your installation is now complete. Thank you for choosing aFe POWER!

**NOTE:** Check all screws, clamps, and connectors are secure after 100-200 miles.



**Page left blank intentionally**



**Page left blank intentionally**

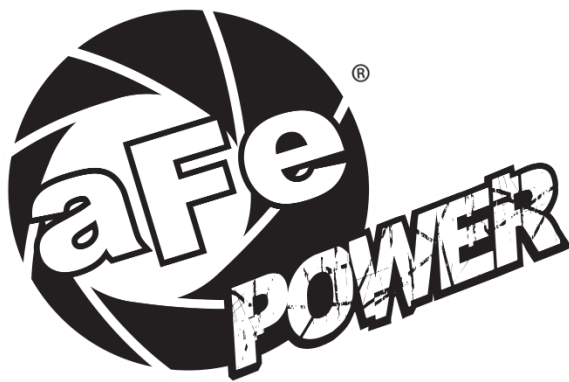

***advanced FLOW engineering, inc.***

252 Granite Street Corona, CA 92879  
TEL: 951.493.7100 • TECH: 951.493.7185  
E-Mail: Tech@aFepower.com

P/N: 50-70080X\_Ins