

advanced FLOW engineering

Cold Air Intake System

Instruction Manual P/N: 50-70063DN

Make: TOYOTA
Make: TOYOTA
Make: TOYOTA
Make: TOYOTA

Model: HILUX
Model: HILUX
Model: FORTUNER
Model: FORTUNER

Year: 2015-2024
Year: 2015-2024
Year: 2015-2024
Year: 2015-2024

Engine: L4-2.8L(td)
Engine: L4-2.4L(td)
Engine: L4-2.8L(td)
Engine: L4-2.4L(td)



- Please read the entire instruction manual before proceeding.
- Ensure all components listed are present.
- If you are missing any of the components, call customer support at 951-493-7185.
- Ensure you have all necessary tools before proceeding.
- Do not attempt to work on your vehicle when the engine is hot.
- Retain factory parts for future use.

Label	Qty.	Description	Part Number
A	1	Air Filter (Pro DRY S) For 50-70063DN	21-91153
B	1	Tube, Rotomold (Orange)	05-5070063N1
C	1	Housing, Rotomold (Orange)	05-5070063N2
D	1	Coupling, Silicone Bellow: (2.75" x 3")ID x 3"L	05-01528
E	1	Clamp, 048 (2-9/16" - 3-1/2 ")	03-50007
F	1	Clamp, 044 (2-5/16" - 3-1/4")	03-50019
G	1	Plug, Silicone : Auxiliary Inlet	05-01429
H	1	Plug, Silicone : Drain hole	03-50766
J	2	Screw, Torx: M4 x .7 x 10mm	03-50490
K	1	Seal, Inlet: Silicone	05-01544

Installation will require the following tools:

8mm, 10mm and 11mm Nut Drivers or Ratchet and Sockets, T20 Driver, Panel Popper or Flathead Screwdriver

Warranty Information available at: <https://afepower.com/contact#warranty>

Emissions Disclaimer: This product does not require a CARB EO# (Vehicle does not exist in U.S.)

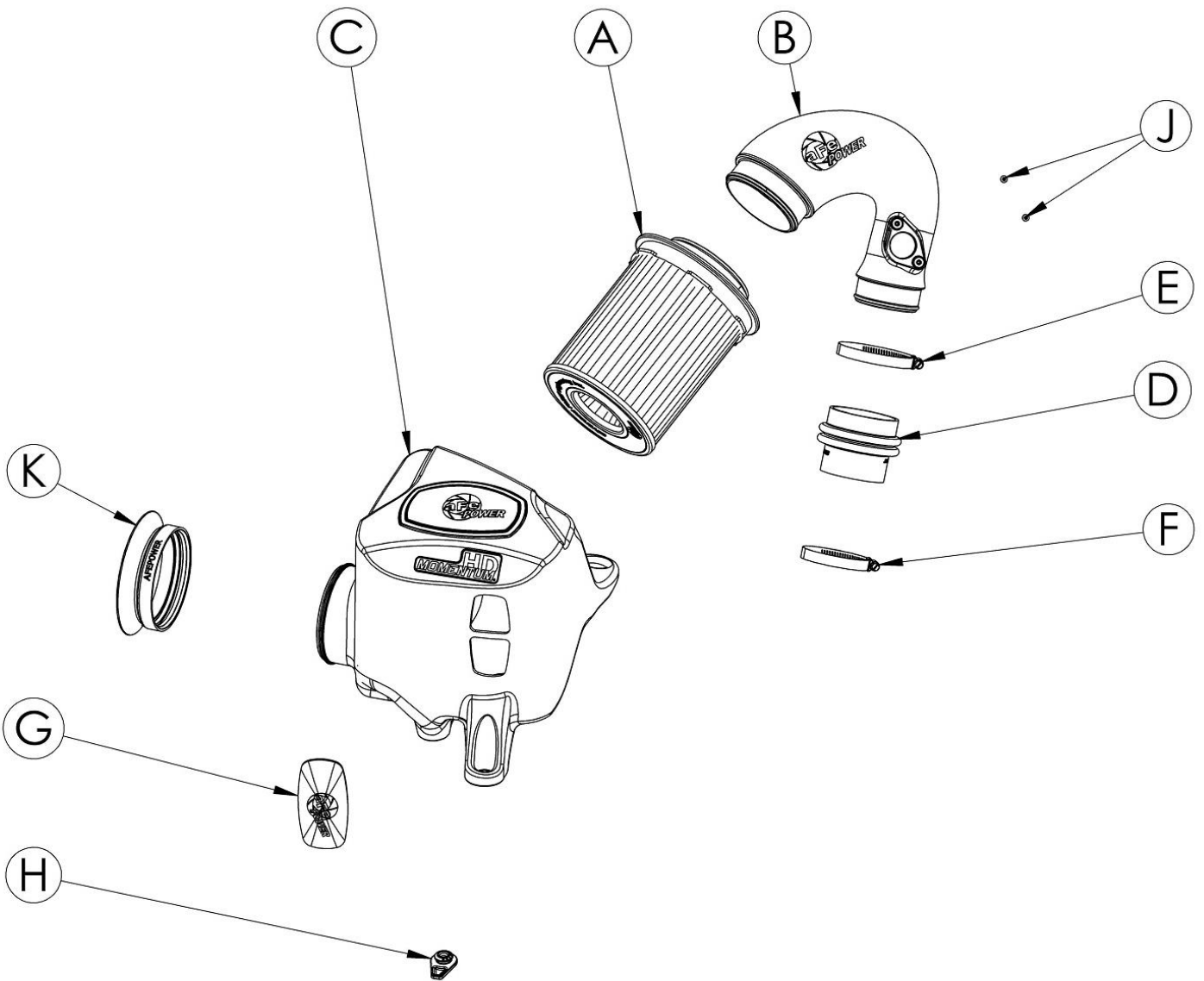

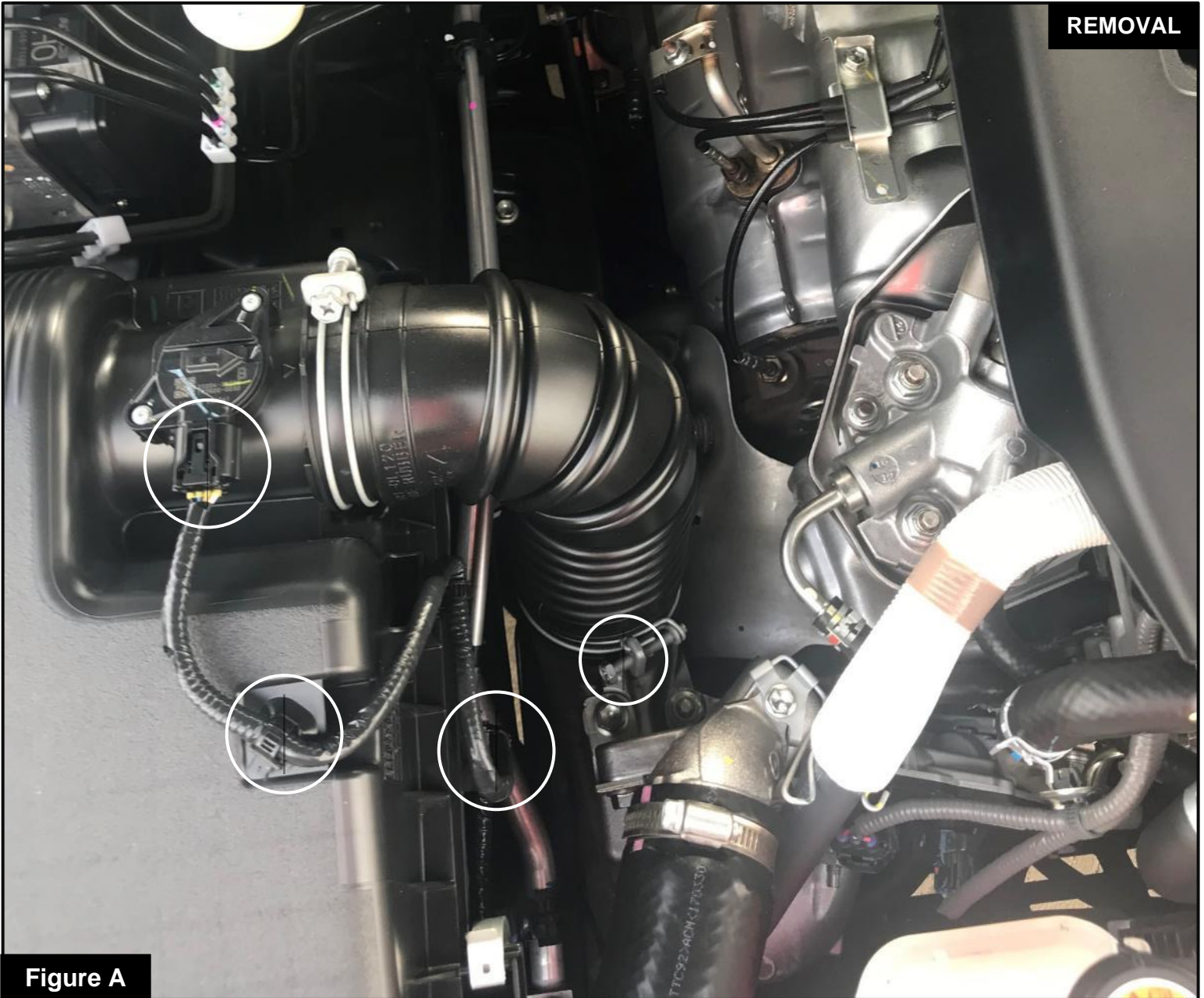
**Figure A****Refer to Figure A for Steps 1-3**

Step 1: Unplug the Mass Air Flow (MAF) sensor harness.

Step 2: Using panel popper tool, detach the harness from the factory air box.

Step 3: Loosen the clamp securing the tube to the turbo inlet.



Figure B

Refer to Figure B for Steps 4-5

Step 4: Remove the 3 screws securing the factory air box (one in the front, one on the fender side and one toward the firewall). Those screws will be reused for the installation of the aFe POWER housing.

Step 5: Remove the factory air box and tube as one piece from the vehicle.

**Figure C****Refer to Figure C for Steps 6-7**

Step 6: Transfer the three factory grommets and sleeves from the factory air box to the aFe POWER housing.

Step 7: Install the aFe POWER plug on the drain hole. This plug can be accessed and removed while the housing is installed on the vehicle.

**Figure D****Refer to Figure D for Steps 8-9**

Step 8: Install the inlet seal onto the air inlet of the aFe POWER housing.

Step 9: Install the air filter into the aFe Power housing by firmly pushing it into the housing until the air filter tabs lock it into place. Install on the clamp on the filter, but do not tighten at this time.



Figure E

Refer to Figure E for Step 10

Step 10: The kit includes an optional plug to close off the side auxiliary air inlet. Install the plug if you wish to close off the side auxiliary air inlet and only capture cold air from the front.

- Without the plug installed, the Momentum air intake will capture the maximum air available. More airflow offers more power. Yet some of this air is picked up from inside the engine compartment and could be warmer air. Warmer air will affect the performance of the vehicle.
- The plug installed on the housing will block off any hot engine air entering the housing and make sure the coolest air available is directed into the engine. It will also reduce the noise of the intake



Figure F

Refer to Figure F for Step 11

Step 11: Install the aFe POWER Housing into the truck and secure it with the 3 screws removed at step 4.

**Figure G****Refer to Figure G for Step 12 (Actual Clamps may vary from picture)**

Step 12: Install the coupling and clamps onto the turbo inlet, the smaller end of the coupling goes on to the turbo inlet. Do not tighten clamps yet.



Figure H

Refer to Figure H for Step 13

Step 13: Transfer the MAF sensor from the factory intake onto the aFe POWER tube and secure with the provided M4 screws.

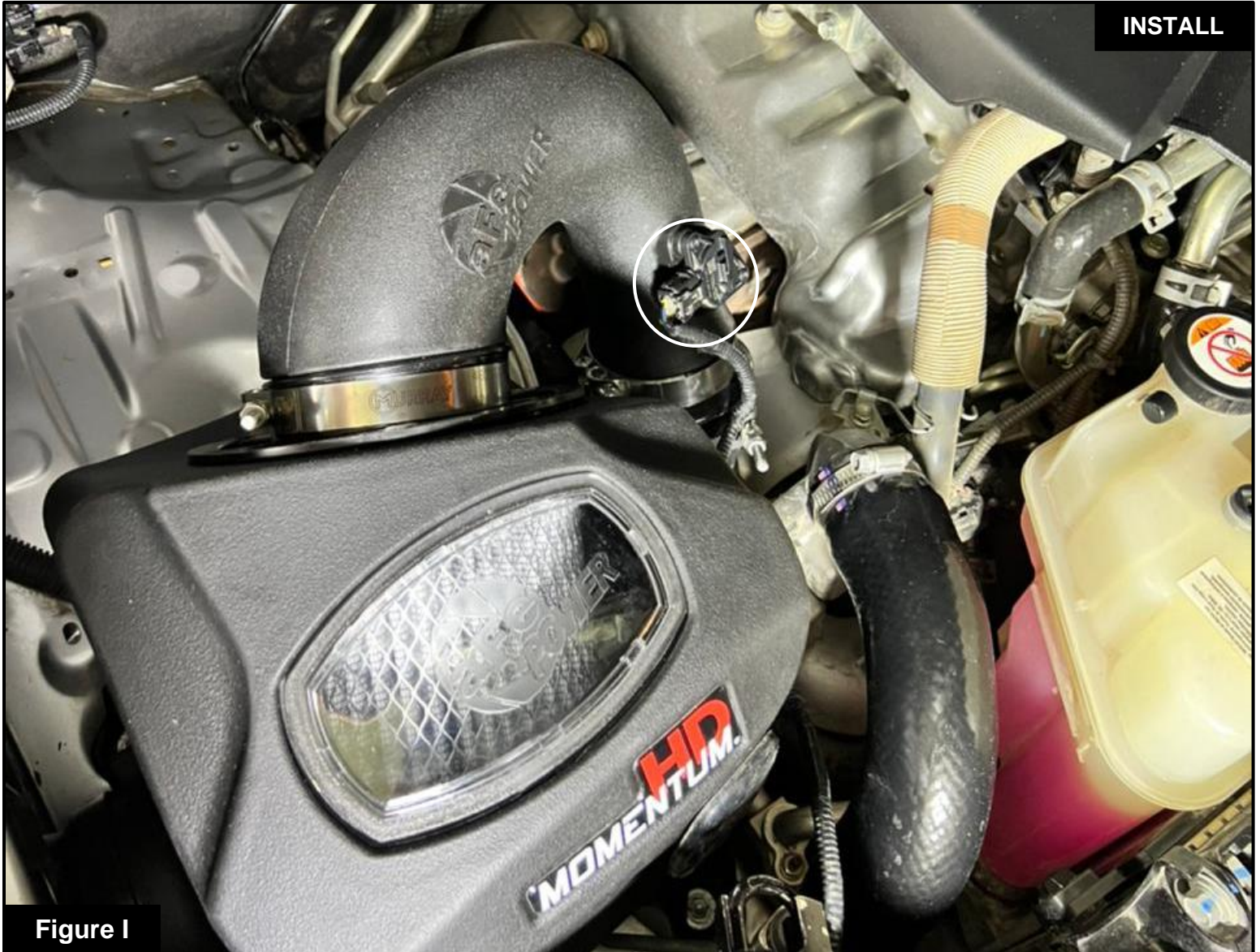
**Figure I****Refer to Figure I for Steps 14-15 (Actual Clamps may vary from picture)**

Step 14: Install the aFe POWER tube into the vehicle by sliding it into the coupling, then into the filter. Align the tube and coupling then tighten all clamps.

Step 15: Reconnect the MAF sensor harness.



Figure J

Refer to Figure J for Step 16 (Actual Clamps may vary from picture)

Step 16: Verify all clamps and connections are secured. Your installation is now complete. Thank you for choosing aFe POWER!



PAGE LEFT BLANK INTENTIONALLY



PAGE LEFT BLANK INTENTIONALLY



advanced FLOW engineering, Inc.

Corona, CA 92879

<https://afepower.com/contact>