



**Product:**

Corvette Johnny O'Connell Signature Sway Bars

**Part Numbers:**

440-401001-J

**Applications:**

Chevrolet Corvette, 1997 - 2013

**Description:**

Johnny O'Connell Signature sway bars.

**Contents in the box:**

- (1) – Front Sway bar with Decal
- (1) – Rear Sway Bar with Decal
- (1) – Bushings kit with grease.
- (1) – Hardware Kit (Note: Flange on locknut replaces washer in diagram)
- (1) – End Links (4 Male 4 Female)

**Difficulty of Installation:** **Beginner** |-----x-----| **Advanced**

**Reason:** This product is a very straight forward to install and requires only basic tools.

**Expected Installation Time:** 1 Hour and 40 Minutes

**Recommended Tools:**

- 18mm box end
- 6mm Allen
- 13mm socket and ratchet
- 18mm socket and ratchet
- 15mm box end
- ¾ box end wrench
- Torque Wrench

## OEM Sway Bar Removal

### Front

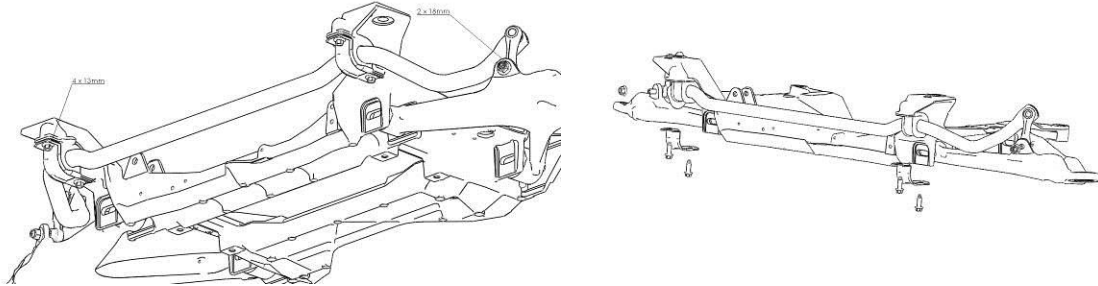

Remove the nuts attaching the end link to the lower control arm using an 18mm box end wrench and a 6mm Allen. Remove the four 18mm bolts attaching the sway bar bushing brackets to the subframe. Remove sway bar and end link assembly.

### Rear

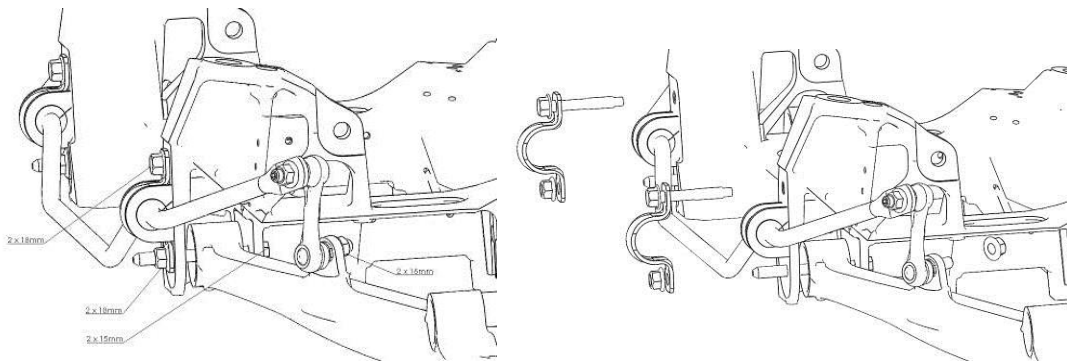

Remove the nuts attaching the end link to the lower control arm using an 18mm box end wrench and a 6mm Allen. Using a 15mm box end wrench and an 18mm socket and ratchet remove the two lower nuts and two upper bolts from the sway bar bushing bracket. Remove the sway bar and end link assembly.

## Installation Procedure

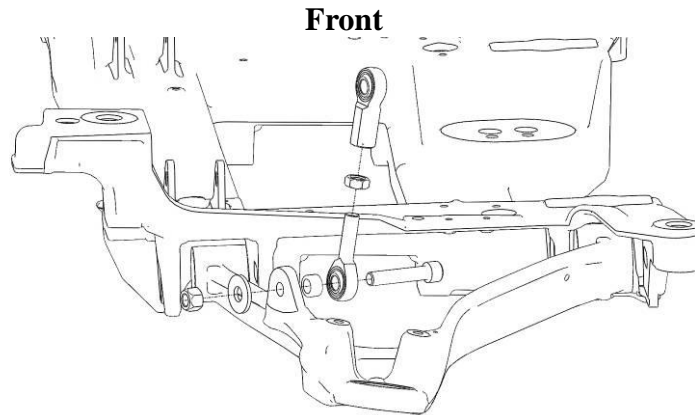

Install the front end links to the front control arms as shown. It is not necessary to tighten the jam nuts on the end links at this point. See **Initial Setup** for end link adjustment.

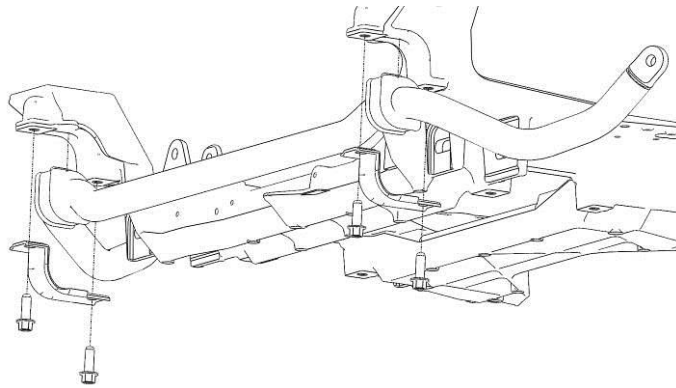

Lubricate the inside of the bushings and the outside of the sway bar where the bushings will rest with the provided grease. Note: Typical automotive grease is not recommended for use on the sway bar bushings.

Using the factory bushing brackets and bolts, install the sway bar onto the subframe. Test the movement of the sway bar. You should be able to rotate the bar by hand with moderate force on the ends of the bar. If it's too tight, place a 1/2" or 12mm washer on the bolts between the brackets and the frame and repeat the process.

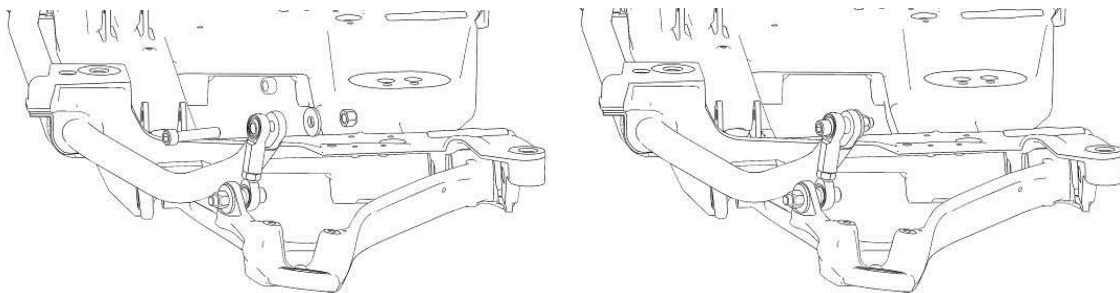

Attach the end links to the sway bar.

## Rear

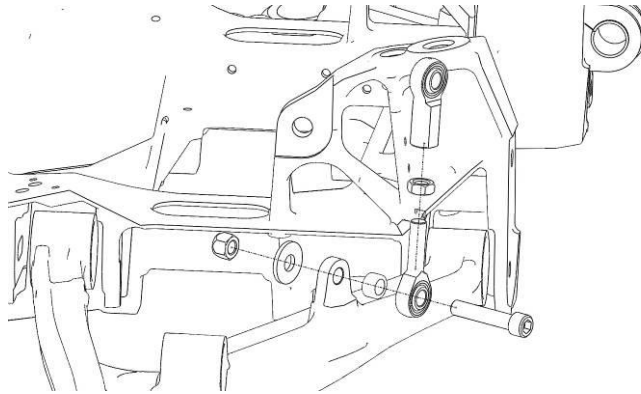

Install the front end links to the rear control arms as shown. It is not necessary to tighten the jam nuts on the end links at this point. See Initial Setup for end link adjustment.

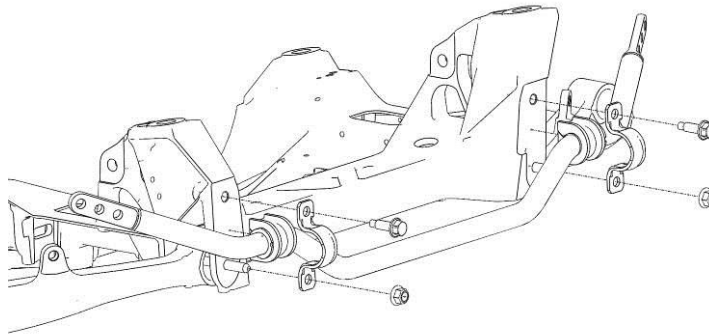

Lubricate the inside of the bushings and the outside of the sway bar where the bushings will rest with the provided grease. Note: Typical automotive grease is not recommended for use on the sway bar bushings.

Using the factory bushing brackets, bolts, and nuts, install the sway bar onto the subframe. Test the movement of the sway bar. You should be able to rotate the bar by hand with moderate force on the ends of the bar. If it's too tight, place a 1/2" or 12mm washer on the bolts between the brackets and the frame and repeat the process.

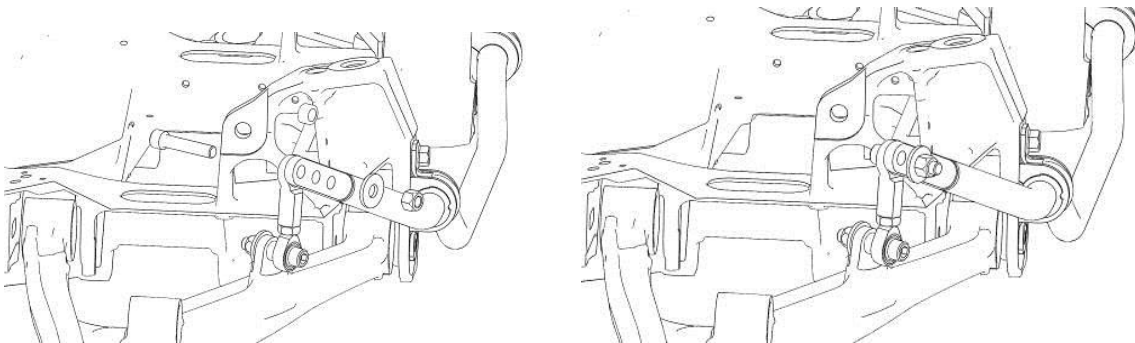

Attach the end links to the sway bar.

## End Link Assembly Diagrams

**Front**

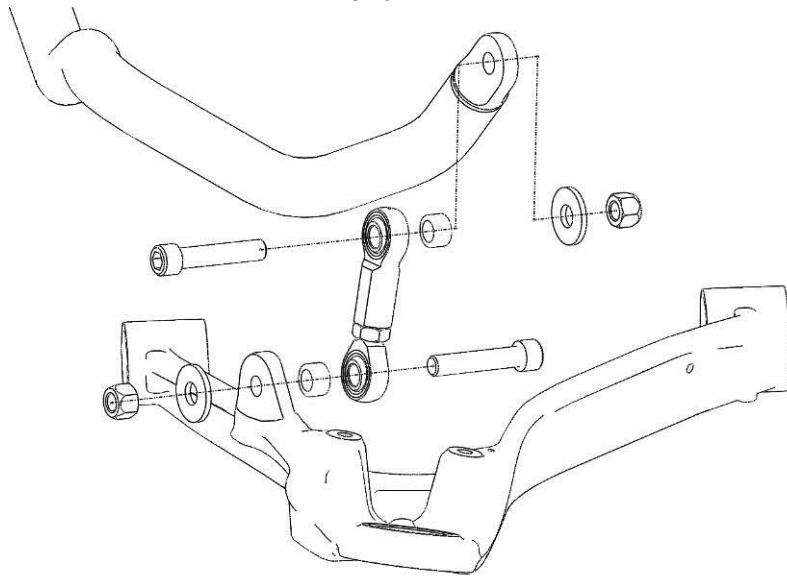

**Rear**

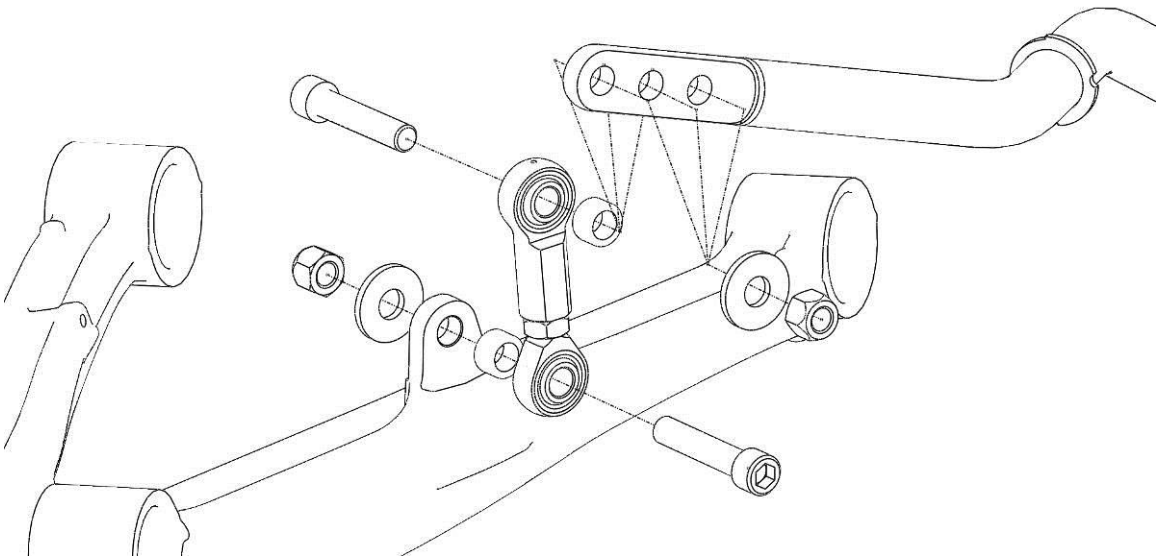

### **Initial setup**

For the initial setting of the sway bars we recommend the middle position on the rear sway bar. For most applications this will be a satisfactory setting and is a good starting point for all cars.

For best performance remove any pre-load in the sway bar while the suspension is loaded by adjusting the end link length. This is best done on a four post lift. It is also possible to set the car down on blocks or ramps so that the end links can be accessed while the suspension is loaded.

After the end link length is adjusted to remove any preload lock down the length by tightening the jam nuts.

### **Fastener Torque**

End Link Bolts and Nuts	68 N-m (50 ft-lbs)
Bushing Bracket Bolts, C6 Z06	46 N-m (34 ft-lbs)
Bushing Bracket Bolts, Non C6 Z06	65 N-m (48 ft-lbs)

Please contact aFe Control Customer Support with any questions!

## Sway Bar Tuning Guidelines

The sway bars are your largest tuning tool and are capable of affecting the balance of the car during each phase of a corner; corner-entry, mid-corner and corner-exit. However, the mid corner section is especially useful for sway bar tuning. Corner-entry and corner-exit are considered transition periods. During these transition periods the shocks are capable of modify the balance of the car. During mid-corner shock setting has no affect on the balance and adjustments are done with the sway bar. In other words, sway bars could correct a corner-entry or corner-exit balance problem but, shocks can not correct a mid-corner balance problem. This is the reason that sway bar tuning should ideally be done during mid-corner.

When tuning sway bars it is best to find a long constant radius turn at which you can incrementally increase speed until the limit of traction is found. There are three possible scenarios at the limit of traction.

1. The front tires exceed their limit of traction first. This condition is commonly called under-steer, push or tight.
2. The rear tires exceed their limit of traction first. This condition is commonly called over-steer, tail-happy or loose.
3. The front and rear tires exceed their limit of traction at the same moment. This condition is commonly called a four-wheel-drift or neutral balance.

After you have determined the behavior of the car it is possible to change this balance by changing the sway bar settings.

Let's take a look at case one for a moment. The front tires are being asked to carry a cornering load higher then they are capable of. However, the rear tires are not being asked to carry as high of a cornering load as they are capable of. By either moving the front sway bar to a softer setting or the rear sway bar to a stiffer setting you will remove some of the cornering responsibility from the front tires and add it to the rear tires.

The general rule of sway bar tuning is to soften the end that needs additional traction. It is also equally as effective to stiffen the end that needs less traction. Typically in the Corvette we generally tune with the rear sway bar because track adjustments on the rear sway bar are easier.

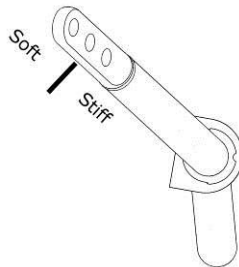



191 Granite Street  
Corona, CA 92879  
951-493-7128  
[www.aFecontrol.com](http://www.aFecontrol.com)